

# COMPANY FACTS AND FIGURES

Phoenix Mecano | Annual Report 2010

## HIGHLIGHTS 2010

IN FINANCIAL YEAR 2010, PHOENIX MECANO SUCCEEDED IN CONSOLIDATING ITS GLOBAL LEADERSHIP POSITION AND CONTINUING ON THE PATH OF DYNAMIC GROWTH. ITS SUSTAINABLE SUCCESS IS FOUNDED ON INTERNATIONALITY, CUSTOMER FOCUS AND ORIENTATION TOWARDS FUTURE MARKETS.

GLOBAL. FLEXIBLE. DYNAMIC.

The Phoenix Mecano Group generated record sales in 2010, up 26.4 % on the previous year.

**501.6** MILLION EUR GROSS SALES

The operating margin was at its highest level in a decade, even outstripping the boom years of 2007 and 2008.

**10.5** % OPERATING MARGIN

The result of the period increased to EUR 43.9 million thanks to cost-cutting measures and successful acquisitions in the reporting year.

**278.3** % INCREASE IN RESULT OF THE PERIOD

# KEY FIGURES OF THE PHOENIX MECANO GROUP

		2010	2009	2008	2007	2006
	Units					
<b>Key financial figures</b>						
<b>Gross sales</b> <sup>1</sup>	EUR million	501.6	396.9	417.3	389.4	346.5
Change	%	26.4	-4.9	7.2	12.4	10.0
<b>Operating cash flow</b> <sup>1</sup>	EUR million	70.4	31.4	59.3	55.1	51.7
Change	%	124.1	-47.0	7.6	6.6	15.8
in % of sales	%	14.0	7.9	14.2	14.2	14.9
<b>Result before interest and tax (Operating result)</b> <sup>1</sup>	EUR million	52.6	13.5	42.8	38.8	35.8
Change	%	288.3	-68.3	10.3	8.4	30.1
in % of sales	%	10.5	3.4	10.3	10.0	10.3
<b>Result of the period</b>	EUR million	43.9	11.6	30.6	30.0	27.8
Change	%	278.3	-62.1	2.1	7.9	415.1
in % of sales	%	8.7	2.9	7.3	7.7	8.0
in % of equity	%	18.6	6.0	16.0	16.4	16.7
<b>Total assets/capital</b>	EUR million	381.4	301.1	294.0	287.6	263.7
<b>Equity</b>	EUR million	236.2	193.4	191.0	182.5	166.9
in % of total assets	%	61.9	64.2	65.0	63.5	63.3
<b>Net indebtedness/(Net liquidity)</b>	EUR million	24.9	-3.8	2.3	4.3	13.0
in % of equity	%	10.5	-2.0	1.2	2.3	7.8
<b>Cash flow from operating activities</b>	EUR million	29.4	46.7	47.6	38.8	25.5
<b>Free cash flow</b>	EUR million	11.7	35.1	29.9	21.7	12.2
<b>Purchases of tangible assets</b>	EUR million	18.3	10.9	15.9	16.3	19.4
<b>Employee numbers</b>						
<b>Number of employees</b> <sup>1</sup>						
annual average		5 929	4 719	4 946	4 891	4 194
<b>Gross sales per employee</b> <sup>1</sup>	EUR 1 000	84.6	84.1	84.4	79.6	82.6
<b>Personnel expenses per employee</b> <sup>1</sup>	EUR 1 000	22.2	24.5	24.2	22.9	24.8
<b>Share indicators</b>						
<b>Share capital</b> <sup>2,3</sup>						
(bearer shares with a par value of CHF 1.00)	Number	978 000	988 000	1 069 500	1 069 500	1 069 500
<b>Shares entitled to dividend</b> <sup>4</sup>	Number	972 541	968 798	989 570	1 038 068	1 067 545
<b>Result before interest and tax (Operating result) per share</b> <sup>1</sup>	EUR	54.1	14.0	43.2	37.4	33.5
<b>Result of the period per share</b>	EUR	45.1	12.0	30.9	28.9	26.0
<b>Equity per share</b>	EUR	242.9	199.6	193.1	175.8	156.4
<b>Free cash flow per share</b>	EUR	12.0	36.2	30.2	20.9	11.5
<b>Dividend</b>	CHF	13.00 <sup>5</sup>	10.00	10.00	9.00	6.00
<b>Share price</b>						
High	CHF	660	420	569	615	570
Low	CHF	404	235	300	474	360
Year-end price	CHF	660	394	317	530	534

<sup>1</sup> The figures for 2006 and 2007 refer to continued operations, i.e. without the discontinued OMP product area.

<sup>2</sup> Pursuant to a decision by the Shareholders' General Meeting of 5 June 2009, the share capital was reduced by CHF 81 500 with effect from 28 September 2009 by cancelling 81 500 shares from the 2007/2008 and 2008/2009 share buyback programmes.

<sup>3</sup> Pursuant to a decision by the Shareholders' General Meeting of 28 May 2010, the share capital was reduced by CHF 10 000 with effect from 2 September 2010 by cancelling 10 000 shares from the 2008/2009 share buyback programme.

<sup>4</sup> As at the balance sheet date, the company owned 5 459 treasury shares, which are not entitled to dividend.

<sup>5</sup> Proposal to the Shareholders' General Meeting of 27 May 2011.

# STRUCTURE OF THE PHOENIX MECANO GROUP

**THE GROUP** Phoenix Mecano is a global player in the enclosures and industrial components segments, has a streamlined operating structure and is a leader in many markets. Geared towards the professional and cost-effective manufacture of niche products, it helps to ensure the smooth operation of processes and connections in the machine industry and industrial electronics. Its products are used in the mechanical engineering, measurement and control technology, alternative energy, medical technology, aerospace technology and home and hospital care sectors, amongst others.

**ENCLOSURES** Standardised and customised enclosures made of aluminium, plastic and glass-fibre reinforced polyester and stainless steel, machine control panels and suspension systems protect sensitive electrical equipment and electronics in mechanical engineering applications. High-quality membrane keyboards offer a reliable human/machine interface, even under extreme conditions.

## OPERATING RESULT AND MARGIN

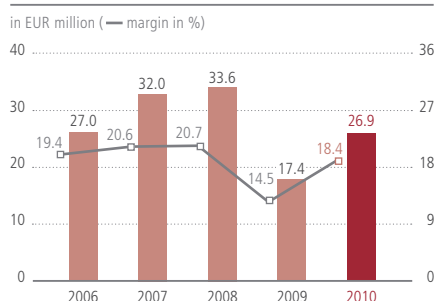

## KEY FIGURES

	2010	2009
in EUR million		
Gross sales	146.5	120.4
Purchases of tangible assets	3.7	2.9
Operating result	26.9	17.4
Margin in %	18.4	14.5

**ELCOM/EMS** Intelligent concepts provide solutions for increasingly complex tasks associated with coding switches and plug connectors, inductive components and toroidal transformers, circuit board equipment, backplanes and the development of customised electronic applications right down to complete subsystems.

## OPERATING RESULT AND MARGIN

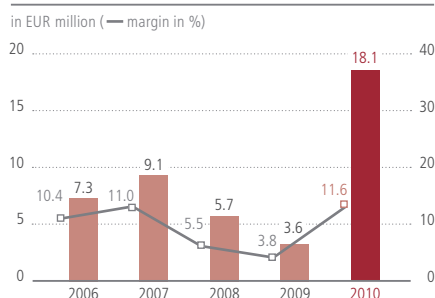

## KEY FIGURES

	2010	2009
in EUR million		
Gross sales	156.1	94.8
Purchases of tangible assets	10.1	2.1
Operating result	18.1	3.6
Margin in %	11.6	3.8

**MECHANICAL COMPONENTS** Aluminium profiles, pipe connection systems, linear drives and conveyor components enable sophisticated systems for use in machine and equipment construction. Reliable, high-performance linear actuators and drive units help to create ergonomic workstations and ensure a high level of user comfort in the home and hospital care sector.

## OPERATING RESULT AND MARGIN

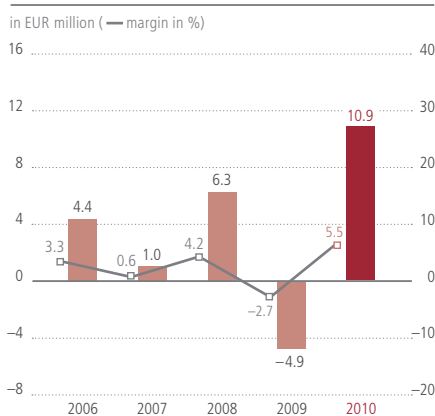

## KEY FIGURES

	2010	2009
in EUR million		
Gross sales	197.4	180.4
Purchases of tangible assets	4.2	5.9
Operating result	10.9	-4.9
Margin in %	5.5	-2.7

# CONTENT



## ENCLOSURES COMPANIES

Bopla Gehäuse Systeme (picture)  
Kundisch  
Rose Systemtechnik



## ELCOM/EMS COMPANIES

Datatel Elektronik	Phoenix Mecano Digital Elektronik
Götz-Udo Hartmann	PTR Messtechnik (picture)
Hartmann Codier	WIENER Plein & Baus
Hartmann Elektronik	



## MECHANICAL COMPONENTS COMPANIES

Dewert Antriebs- und Systemtechnik  
Okin Motion Technologies  
RK Rose + Krieger (picture)

02 Report by the Board of Directors

## 06 COMPANY INFORMATION

08 Management report – Phoenix Mecano Group  
16 Management report – Enclosures  
20 Management report – ELCOM/EMS  
24 Management report – Mechanical Components  
28 Share information  
32 Sustainability report  
38 Corporate governance

## 54 INFORMATION ON THE FINANCIAL STATEMENTS

56 Phoenix Mecano Group financial report 2010  
117 Report of the statutory auditor  
on the consolidated financial statements  
119 Five-year overview  
120 Phoenix Mecano AG financial report 2010  
130 Proposal for the appropriation  
of retained earnings  
131 Report of the statutory auditor  
on the financial statements

## 133 INTERNATIONAL PRESENCE

134 Phoenix Mecano Group locations  
136 Addresses



From left to right:  
**Ulrich Hocker**  
Chairman of the Board of Directors  
**Benedikt A. Goldkamp**  
Delegate of the Board of Directors

## DEAR SHAREHOLDERS,

2010 was an extremely successful year for the Phoenix Mecano Group, with record sales, operating result and net result. There are a number of reasons for this remarkable performance. Some of the success is owing to the hard work of employees and the management team. However, we also benefited from the favourable external conditions during the reporting year. At the start of 2010, almost all market analysts agreed that the biggest global economic crisis since the 1930s, triggered by the financial crisis of 2008, was far from over. Despite some positive leading indicators, caution was the name of the game, and only a few industrial companies were planning significant capacity increases and plant expansions. Consequently, the sudden upturn in the economy in spring 2010 caught many market players completely off guard.

Phoenix Mecano has a well-structured and flexible logistics and supply chain, while its own internal production capacity – strategically distributed around the globe – was able to increase its capacity quickly thanks to ongoing capital expenditure programmes. The short-time working arrangements introduced as a means of retaining core skilled staff also paid off.

As a result, in a year of economic recovery characterised by supply bottlenecks, the Group was able not only to keep pace with the market but also to acquire new customers and markets shares thanks to its high supply capability.

---

Phoenix Mecano generated record sales in 2010, and the best net result in its history. Operating result soared by 288.3 %, from EUR 13.5 million to EUR 52.6 million.

**288.3** % INCREASE IN OPERATING RESULT

### Successful integration of acquisitions

The Group's newly acquired companies also contributed to its success. The Okin electrical drives business for the furniture industry, acquired in 2009, was successfully integrated and brought into the black. The bolt-on acquisition of Lohse GmbH, which specialises in toroidal strip-wound cores used in chokes and toroidal transformers, generated added value in the booming market for photovoltaic inverter components. Towards the end of the year, the Group also established a joint venture in China. This will boost the furniture and medical drive technology business under the Dewert and Okin brands. In addition to a well-functioning production base in China, the joint venture gives the Phoenix Mecano Group substantial sales capacity for the growth markets of the Far East.

### **Growth driven by emerging economies and capital goods markets**

The Group's strong future prospects are based on its continually expanding presence in the up-and-coming growth markets of the Far East and Latin America. Through subsidiaries, Phoenix Mecano has been active in Brazil for over 30 years and in China and India for over 15 years. Our early involvement in these countries means that we are solidly placed to tap into their rapidly growing market potential by means of targeted investments. Our experienced local teams support and safeguard these new investments, which are only possible thanks to our long-established presence in these markets.

However, the rise of Asia and Latin America is not only reflected in the double-digit growth rates of our sales companies there. Export-led sectors in Europe, especially capital goods manufacturers in Germany and Switzerland (who remain the Group's largest customer segment), are benefiting massively from the development of new infrastructure in the emerging economies. In other words, Phoenix Mecano is exploiting growth in these regions in more ways than one: via direct sales by its own subsidiaries and via export-led industrial customers in Europe.

2010 GROWTH YEAR

Aside from the cyclical recovery in many industrial markets, the main drivers of the sales growth were the well-structured and flexible logistics and supply chain, the rigorously implemented cost-cutting measures and the successful integration of acquisitions Okin and Lohse.

### **Dividend**

Phoenix Mecano has strong and growing cash flows, a solid balance sheet and a low level of debt. Our dividend policy is geared towards continuity, and the logic of that policy dictates an increase in dividend. We will therefore propose a dividend of CHF 13.00 per bearer share to the Shareholders' General Meeting – an increase of 30 %.

### **A big thank you to our employees**

Phoenix Mecano grew strongly in 2010. It employed an average of 5 929 staff, some 26 % more than the previous year. The fact that the new employees were able to contribute so quickly to the Group's success is testimony to the dedication of our loyal and experienced core workforce, who not only perform their own tasks with remarkable motivation and competence but at the same time pass on their knowledge and experience to new members of the team. This level of commitment is not a given: it is part of the culture that sets the Phoenix Mecano Group apart. We would therefore like to extend our warmest thanks to each and every one of these dedicated employees.



### Looking ahead

The recovery from the severe recession of 2008 to 2009 is increasingly extending to late-cycle sectors and can now be described as broad-based. The European mechanical engineering sector in particular is expecting further significant growth rates compared with 2010. As an excellently positioned supplier for this sector, Phoenix Mecano will benefit from that growth. However, there are also some leading indicators suggesting another downturn, which need to be monitored closely. The first of these is the increased geopolitical uncertainty caused by recent events in the Middle East (dubbed the 'jasmine revolution' by the media), which has already had a significant impact on oil prices. Secondly, the poor state of public finances in Europe and the USA will have a negative effect on state-subsidised sectors over the coming years. The main factor to watch will be how the renewable energies market, which has boomed massively in recent times, will react to any such development. The recent events in Japan are not expected to have any direct impact on Phoenix Mecano. In the medium term, the renewed discussions in Europe about an accelerated withdrawal from nuclear energy could have positive repercussions for the photovoltaic sector, which would benefit Phoenix Mecano as a supplier of inverter components. As in the past, the Group will continue to concentrate on using its flexible structure, solid balance sheet and high cash flow to exploit possible cycles in order to improve its market position and expand its portfolio of expertise. In other words, both economic upturns and downturns offer equal opportunities to create value for you, our esteemed shareholders. In the meantime, we expect the favourable environment to continue in 2011, enabling us to achieve a further increase in sales and operating result compared with the record year of 2010.

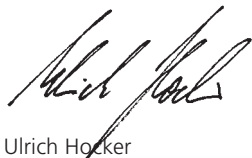

Ulrich Hoeker  
Chairman of the Board of Directors



Benedikt A. Goldkamp  
Delegate of the Board of Directors

## COMPANY INFORMATION

PHOENIX MECANO IS A GLOBAL TECHNOLOGY ENTERPRISE ACTIVE IN THE ENCLOSURES AND INDUSTRIAL COMPONENTS SECTORS. WORKING WITH AND FOR OUR CUSTOMERS, WE DEVELOP INNOVATIVE AND DETAILED TECHNICAL SOLUTIONS. WE HAVE ESTABLISHED A SUCCESSFUL GLOBAL PRESENCE THROUGH OUR CUTTING-EDGE PRODUCTS AND CUSTOMER-DRIVEN SERVICE.

GLOBAL. FLEXIBLE. DYNAMIC.

Operating result rose by 288.3 % from EUR 13.5 million to EUR 52.6 million.

**52.6** MILLION EUR OPERATING RESULT

Consolidated incoming orders climbed to EUR 522.5 million in 2010, an increase of EUR 115 million compared with the previous year.

**104.2** % BOOK-TO-BILL RATIO

Operating cash flow (EBITDA) was up by 124.1 % on the previous year, at EUR 70.4 million.

**70.4** MILLION EUR OPERATING CASH FLOW

Capital that is not required for development of the business is returned to shareholders. In view of the year's record sales, we will propose to the Shareholders' General Meeting of 27 May 2011 a dividend of CHF 13.00 per share.

**13.00** CHF DIVIDEND PER SHARE

## PHOENIX MECANO GROUP

BEST RESULT IN THE  
COMPANY'S HISTORY.  
FURTHER PROGRESS  
EXPECTED IN THE CURRENT  
FINANCIAL YEAR.

## Gross sales

in EUR million

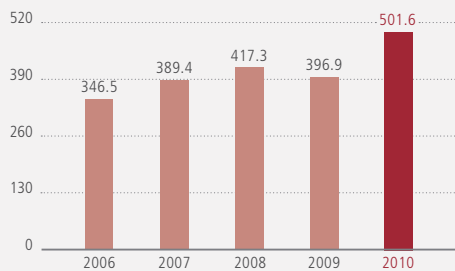

## Operating result and margin

in EUR million (— margin in %)

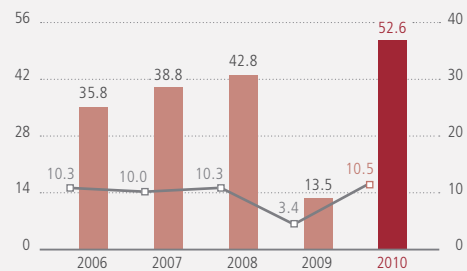

## Gross sales by region

in %

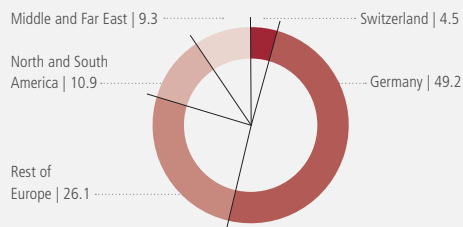

## Gross sales by division

in %

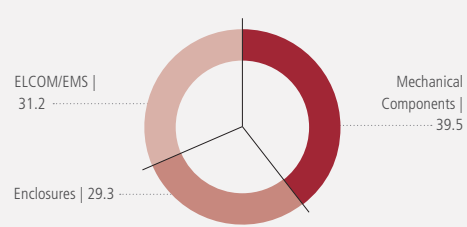

## OVERVIEW OF THE FINANCIAL YEAR

**In a significantly improved market environment, the Phoenix Mecano Group increased its sales by 26.4 % to EUR 501.6 million and its incoming orders by 28.2 % to EUR 522.5 million. Operating result soared by 288.3 % to EUR 52.6 million. In addition to the cyclical recovery, the Group also benefited in 2010 from the rigorous cost-cutting measures implemented the previous year. The operating margin was 10.5 % while the result of the period reached a record high of EUR 43.9 million. The equity ratio stood at 61.9 %; net indebtedness as a percentage of equity was 10.5 %.**

## BUSINESS ACTIVITIES

The economic recovery already in evidence at the end of 2009 gathered momentum during the first half of 2010, allowing the Phoenix Mecano Group to return to the growth trajectory of 2007 and 2008. The unexpectedly dynamic sector-wide recovery proved a major stress test for the Group's internal procurement, logistics, production and project management processes. The rigorous cost-cutting measures implemented in 2009 and ongoing implementation of the Group's capital expenditure policy throughout the crisis enabled rapid progress in the reporting year: the Group attained its highest ever profitability with its current corporate structure and in some cases increased its market share by being better able to supply than its competitors. Its excellent liquidity position and strong balance sheet enabled it both to finance dynamic growth in its core business and to exploit opportunities for strategic bolt-on acquisitions. Its core workforce, which remained largely intact during the crisis thanks to flexible short-time working arrangements, proved a vital asset in the recovery phase. The short-time working schemes were gradually phased out over the first half of the year as demand picked up. In fact, in the booming photovoltaic inverter components market in particular, a substantial increase in employee numbers was required.

### **Completion of Okin integration**

Following the Group's takeover of parts of the insolvent linear drive manufacturer Okin in 2009, a restructuring of the linear drives business for the furniture and care industry was completed successfully and on schedule in 2010. All furniture industry activities are now united under the Okin brand, including the Group activities of subsidiary Dewert. As a result, the Phoenix Mecano Group is now the world's leading manufacturer of electrical linear drives for electrically adjustable seating and reclining furniture. Via the well-positioned Dewert brand, Phoenix Mecano is also the world's second largest producer of electrical adjustable drives for the hospital and care industry.

### **Successful expansion of solar activities**

The inverter components production business, which the Group entered in early 2008, saw dynamic growth in the reporting year. The Group generated total sales of some EUR 70 million in the sector, more than doubling its volume in this market of the future. The acquisition of Lohse GmbH in the first half of 2010 offers great scope for boosting value-added in the sector. The toroidal strip-wound and air-gap cores manufactured by Lohse are used in toroidal transformers and chokes for inverters. In the coming years, there will also be additional market potential for these products as components in instrument transformers, which will play a key role in the required expansion of electricity grids and energy infrastructure.

### Increased involvement in emerging economies

The dynamic market growth in emerging economies, most notably the BRIC countries (Brazil, Russia, India and China), also resulted in extremely positive sales development for Phoenix Mecano. High double-digit organic growth rates required an expansion of capacity in these markets. As well as recruiting technically adept sales specialists in all BRIC countries, the Group expanded its presence in the growth markets of Asia by founding a 90 % joint venture in China, Okin Refined Electric Technology (ORE), in December 2010. The joint venture developed strongly in its first few months and has been profitable from the outset.

### Long-term strategy continued

The improved global economy and the exceptional dynamism of the emerging markets offers Phoenix Mecano excellent development opportunities in the coming years. Enabling technologies and standard components developed in Europe are, and will continue to be, complemented by the local consultancy and development expertise of customers in end markets. The Group's production locations, well distributed around the world, and the global sourcing programmes it has developed and expanded gradually since the early 1990s mean that we are able to react flexibly, even in rapidly changing market conditions, and bring products and technical services to market in a competitive way, via short information and logistics paths. One positive spin-off of this global diversification approach is the well-developed natural hedge it provides against monetary turbulence. At Phoenix Mecano, there is an almost perfect natural balance between costs and sales in the various currency areas. Such a structure is not unusual in large global corporations, but for a medium-sized industrial group it offers a clear competitive advantage, only made possible by Phoenix Mecano's consistent efforts to internationalise the Group over the past 30 years and more. We will continue to pursue this strategy rigorously in the coming years, to ensure that the benefits of these long-term efforts can be exploited ever more effectively, including at our European sites.

## SALES AND PROFITABILITY

### Record sales

The Phoenix Mecano Group's consolidated gross sales rose by 26.4 % in 2010, from EUR 396.9 million to a record high of EUR 501.6 million. Corrected for differences in foreign-exchange rates, sales were up by 24.1 %. Corrected for changes in scope, sales were up by 24.5 %. The main drivers of this positive development were the significantly improved economic environment for industrial goods and strong growth in the photovoltaic sector. Thanks to its sound positioning, Phoenix Mecano was able to benefit from the economic recovery in a broad range of areas.

26.4 % SALES INCREASE

In a significantly improved market environment, the Phoenix Mecano Group increased its sales by 26.4 % to EUR 501.6 million. In the Russian and Chinese markets, sales rose by over 60 %. Sales in Europe were up by 24.7 %.

Gross sales by region		2010	2009
	Change in %	1 000 EUR	1 000 EUR
Switzerland	37.2	22 660	16 511
Germany	30.9	246 708	188 507
UK	2.6	15 449	15 061
France	-1.5	22 443	22 786
Italy	27.1	14 842	11 676
Benelux	5.9	23 076	21 790
Rest of Europe	23.6	55 152	44 636
North and South America	32.4	54 424	41 121
Middle and Far East	34.4	46 804	34 825
<b>Total</b>	<b>26.4</b>	<b>501 558</b>	<b>396 913</b>

Gross sales by division		2010	2009
	Change in %	1 000 EUR	1 000 EUR
Enclosures	21.7	146 460	120 376
ELCOM/EMS	64.6	156 091	94 822
Mechanical Components	9.5	197 419	180 352
<b>Total for all divisions (segments)</b>	<b>26.4</b>	<b>499 970</b>	<b>395 550</b>
Reconciliation <sup>1</sup>	16.5	1 588	1 363
<b>Total</b>	<b>26.4</b>	<b>501 558</b>	<b>396 913</b>

<sup>1</sup> Included under Reconciliation are individual business areas and central management and financial functions that cannot be allocated to the divisions.

In Europe, sales increased by 24.7 % (23.4 % in organic terms). This was driven mainly by growth in the key capital goods markets of Germany, Austria, Italy and Switzerland. Due to the still slightly stronger growth dynamic in overseas markets, the proportion of overall sales realised in Europe fell slightly from 80.9 % to 79.8 %. The highest levels of sales were generated in Russia and China, which both saw increases of over 60 %. In Russia, this was owing mainly to success in the oil and gas business; in China, sales increased across the board.

All three divisions contributed to the Group's sales growth. Despite a delayed recovery in late-cycle segments, the Enclosures division succeeded in increasing its sales by 21.7 % in 2010. The ELCOM/EMS division achieved dynamic sales growth of 64.6 % (63.3 % in organic terms). This division benefited heavily from the booming photovoltaic industry as well as from increased demand for electrotechnical components generally. Sales in the Mechanical Components division were up by 9.5 %. Adjusted for acquisitions, growth totalled 6.1 %. In this division, declines in sales of linear drives for the furniture industry in some European markets were offset by substantial increases in sales of linear drives in overseas markets as well as globally in the industrial components business.

Consolidated incoming orders for the Phoenix Mecano Group totalled EUR 522.5 million, compared with EUR 407.5 million the previous year. The rate of increase was 28.2 %, slightly higher than that of sales. The book-to-bill ratio (incoming orders as a percentage of gross sales) was 104.2 %, compared with 102.7 % the previous year.

# 104.2 % BOOK-TO-BILL RATIO

All three divisions contributed to the Group's sales growth, with the ELCOM/EMS division recording the most dynamic growth. The Phoenix Mecano Group's consolidated incoming orders totalled EUR 522.5 million, compared with EUR 407.5 million the previous year.

### Operating result exceeds 2008 level

Operating result soared by 288.3 % in 2010, from EUR 13.5 million to EUR 52.6 million, more than making up for the 68.3 % decline recorded the previous year. The operating margin was 10.5 % (3.4 % the previous year), outstripping the boom years of 2007 (10.0 %) and 2008 (10.3 %).

All three divisions delivered a greater contribution to the result and increased their operating margin and profitability. The profitability of the Enclosures division was almost back to the levels recorded in 2007 and 2008, while in the other two divisions it actually exceeded them.

Operating result by division		2010	2009
	Change in %	1 000 EUR	1 000 EUR
Enclosures	54.6	26 940	17 428
ELCOM/EMS	400.5	18 148	3 626
Mechanical Components	324.4	10 929	-4 871
<b>Total for all divisions (segments)</b>	<b>246.1</b>	<b>56 017</b>	<b>16 183</b>
Reconciliation <sup>1</sup>	-29.7	-3 425	-2 640
<b>Total</b>	<b>288.3</b>	<b>52 592</b>	<b>13 543</b>

<sup>1</sup> Included under Reconciliation are individual business areas and central management and financial functions that cannot be allocated to the divisions.

Profitability by division		2010	2009
	Change in % points	in %	in %
Enclosures	14.3	44.7	30.4
ELCOM/EMS	13.1	20.3	7.2
Mechanical Components	14.4	9.0	-5.5



Use of materials as a percentage of gross sales (material use rate) remained stable in the reporting year. This was despite the material use rate for products in the photovoltaic segment – whose sales doubled in 2010 – being above the Group average, and despite increases in the price of raw materials and certain starting materials used in industrial electronics, which were subject to supply bottlenecks.

Personnel expenses rose under-proportionally to sales growth by 13.9 % in the reporting year. Average staff numbers over the year rose from 4 719 to 5 929. In line with sales growth, the biggest increase in staff numbers was in the ELCOM/EMS division, which employed 2 570 staff (previous year 1 702), with the biggest regional increases at production sites in Tunisia (+564) and Hungary (+343).

Depreciation on tangible assets fell by EUR 0.6 million (–4.3 %) due to the reduced volume of capital expenditure in 2009. Amortisation of intangible assets rose by EUR 0.6 million (+16.6 %), mainly owing to additions of amortisable intangible assets totalling EUR 16.8 million associated with the acquisitions completed in 2010.

Other operating expenses increased only slightly in the reporting year, by 2.9 %. In line with the increase in sales, establishment expenses rose by EUR 3.4 million (21.8 %) and advertising and sales expenses by EUR 3.9 million (31.6 %). On the other hand, there was a significant reduction in impairment losses on intangible and tangible assets (EUR –1.7 million) as well as losses and value adjustments on inventories (EUR –3.7 million).

#### Best ever net result

The financial result was EUR –1.7 million, down on the previous year's total of EUR +0.3 million. Following a net exchange rate gain of EUR 0.4 million in 2009, 2010 saw a net exchange rate loss of EUR 0.6 million. The reporting year also saw expenses of EUR 0.3 million owing to the revaluation of residual purchase price liabilities from companies acquired in previous years as well as a EUR 0.5 million loss from the disposal of Group company IPES Industria de Produtos e Equipamentos de Solda Ltda., which was not part of the Group's core business. By contrast, the net interest result contained in the financial result was significantly improved at EUR –0.5 million (previous year EUR –0.9 million).

At 13.7 % (previous year 16.3 %), the income tax rate in 2010 was below the multi-year average, mainly owing to tax income relating to other periods arising from the disappearance of tax risks from earlier financial years.

The result of the period rose by 278.3 % in 2010, from EUR 11.6 million to an all-time high of EUR 43.9 million. The net margin rose to 8.7 % (previous year 2.9 %), topping even the 2008 level (7.3 %).

The result of the period increased by 278.3 % in 2010, from EUR 11.6 million to an all-time high of EUR 43.9 million.

**43.9** MILLION EUR RESULT OF THE PERIOD

## ASSET AND CAPITAL STRUCTURE

### Increased capital expenditure

Purchases of tangible assets in the reporting year totalled EUR 18.3 million, compared with EUR 10.9 million the previous year. Purchases of intangible assets totalled EUR 1.3 million, compared with EUR 1.2 million the previous year. The sharp increase in capital expenditure is attributable largely to the expansion of photovoltaic production capacity in Hungary.

Due to the increased capital expenditure and the expansion of inventories (primarily intended to boost supply capability), the net assets of the three divisions increased by a total of 38.7 %, from EUR 195.8 million to EUR 271.6 million.

Purchases of tangible assets	2010	2010	2009	2009
	1 000 EUR	in %	1 000 EUR	in %
<b>By type of asset</b>				
Land and buildings	912	5.0	2 912	26.6
Machinery and equipment	9 316	50.9	4 900	44.8
Tools	1 800	9.8	1 735	15.8
Advance payments and construction in progress	6 268	34.3	1 396	12.8
<b>Total</b>	<b>18 296</b>	<b>100.0</b>	<b>10 943</b>	<b>100.0</b>
<b>By division</b>				
Enclosures	3 713	20.3	2 901	26.5
ELCOM/EMS	10 052	54.9	2 053	18.8
Mechanical Components	4 236	23.2	5 853	53.5
<b>Total for all divisions (segments)</b>	<b>18 001</b>	<b>98.4</b>	<b>10 807</b>	<b>98.8</b>
Reconciliation <sup>1</sup>	295	1.6	136	1.2
<b>Total</b>	<b>18 296</b>	<b>100.0</b>	<b>10 943</b>	<b>100.0</b>

<sup>1</sup> Included under Reconciliation are individual business areas and central management and financial functions that cannot be allocated to the divisions.

Net operating assets by division		2010	2009
	Change in %	1 000 EUR	1 000 EUR
Enclosures	5.2	60 310	57 348
ELCOM/EMS	81.9	89 589	49 247
Mechanical Components	36.4	121 718	89 242
<b>Total for all divisions (segments)</b>	<b>38.7</b>	<b>271 617</b>	<b>195 837</b>
Reconciliation <sup>1</sup>		-35 391	-2 472
<b>Total</b>	<b>22.2</b>	<b>236 226</b>	<b>193 365</b>

<sup>1</sup> Included under Reconciliation are individual business areas and central management and financial functions that cannot be allocated to the divisions.

**Equity ratio remains high**

Due to the 26.7 % increase in total assets, the equity ratio fell slightly to 61.9 % (previous year 64.2 %), despite the high result of the period for 2010.

**Acquisition-related increase in net indebtedness**

The Group's cash and cash equivalents and current securities having exceeded its total interest-bearing liabilities for the first time in 2009, as at 31 December 2010 there was once again a net indebtedness of EUR 24.9 million. In addition to the liquidity required for capital expenditure and the inventory increase, this was mainly owing to the two acquisitions made in the financial year. On 1 May 2010, the Phoenix Mecano Group acquired full ownership of Lohse GmbH, Muggensturm (D). With effect from 22 November 2010, the Phoenix Mecano Group acquired a 90 % stake in the newly founded joint venture Okin Refined Electric Technology Co. Ltd. based in Jiaxing City, China. The liquidity outflow for these two acquisitions was EUR 18.9 million in the reporting year. In addition, there were residual purchase price liabilities totalling EUR 17.0 million at the balance sheet date, which are included in the net indebtedness. The net indebtedness was a moderate 10.5 % of equity.

## OUTLOOK

The market environment for technical components manufacturers has improved significantly in Europe, Asia and most recently the USA. The economic indicators suggest that the recovery phase witnessed in 2010 could be followed by a growth phase, for which our company is well positioned. Uncertainties exist owing to the massive increase in industrial metal prices, which will result in higher material costs, particularly in the electronics and electrical engineering sectors. As we know from past experience, passing on the costs to end markets will only work in part, owing to the global competition that exists in these sectors. The current unrest in north African countries is also pushing up the price of petroleum-based plastics and energy costs. Furthermore, the debt situation in many industrialised nations is creating uncertainty about the further expansion of renewable energy infrastructure, particularly in the photovoltaic sector where some significant cuts in subsidies are planned for 2011. The effects of these are difficult to assess at present. Although these factors must be taken into account, they do not alter our fundamentally positive expectations for 2011. As far as can be ascertained today, the increased willingness to invest prompted by the global economic recovery should enable Phoenix Mecano to improve its sales and operating profit once again this year.

PHOENIX MECANO ENCLOSURES

# DYNAMIC DEVELOPMENT AND OVER-PROPORTIONAL INCREASE IN PROFIT DUE TO COST MANAGEMENT.

**Gross sales**

in EUR million

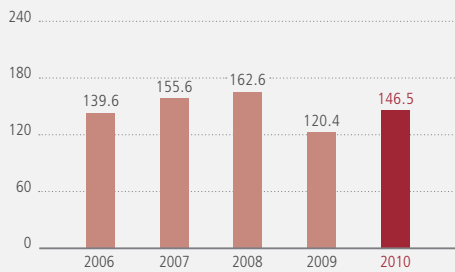

**Operating result and margin**

in EUR million (— margin in %)

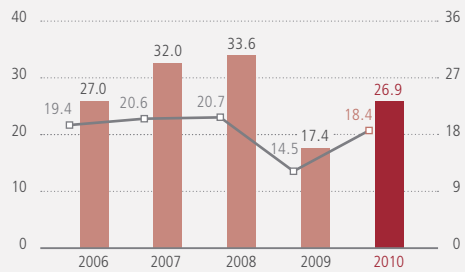

**Gross sales by region**

in %

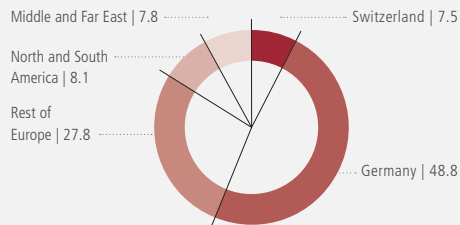

**Purchases of tangible assets**

in %

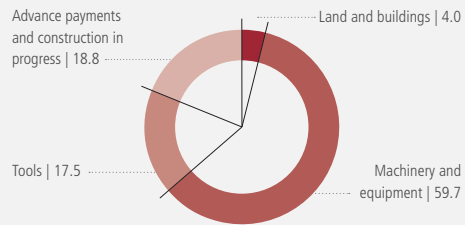

## OVERVIEW OF THE FINANCIAL YEAR

**In a revitalised economic environment, the division's sales increased by 21.7 %. Operating result rose over-proportionally by 54.6 %. Operating margin and profitability were nearly back to the high levels recorded before the economic crisis.**

## SALES AND PROFITABILITY

### Sales

The Enclosures division saw its gross sales increase by 21.7 % in 2010, to EUR 146.5 million (19.7 % when corrected for differences in foreign exchange rates). Sales developed very positively in the key capital goods markets of Central Europe, in Eastern Europe and in particular Russia, in North and South America and in India and China. In the other Asian markets, sales development was uneven due to fluctuations in the project business. Sales in France declined.

Sales of industrial enclosures (including control panels and carriers) rose by 19.4 % in 2010. Economic development in individual sectors was mixed. While a very positive trend was observable in industrial electronics and measurement and control technology, the upturn in traditional machine tool manufacturing was subdued. Over-proportional growth was achieved in the renewable energies sector (wind technology and photovoltaics). The positive trend in project business involving explosion-proof products continued in 2010. In this field of applications, the year saw increased deployment of new plastic products alongside stainless-steel enclosures, with some very successful product launches.

Sales of membrane keyboards developed very dynamically in the key sectors of mechanical engineering, control systems and automation. In addition, the medical and solar technology sectors saw increases in orders. Overall sales of membrane keyboards were up by 44.6 %. As regards product mix, there was a shift towards systems with touchscreen integration.

### Orders

The division's incoming orders in the reporting year were up 32.1 % on the previous year, at EUR 154.3 million. The book-to-bill ratio (incoming orders as a percentage of gross sales) stood at 105.3 %, compared with 97.0 % in 2009. After a relatively slow Q1 2010, the economic recovery began to gather pace from Q2 and the division's current market environment remains favourable.

### Result

The pleasing growth in sales combined with an under-proportional increase in costs resulted in a 54.6 % increase in operating result to EUR 26.9 million. The division benefited from the rigorous cost-cutting measures implemented the previous year. The rate of use of materials remained stable and depreciation fell slightly. At 18.4 % (previous year 14.5 %), the operating margin was almost back to pre-crisis levels.

Gross sales by region		2010	2010	2009	2009
	Change in sales in %	Sales 1 000 EUR	Share of sales in %	Sales 1 000 EUR	Share of sales in %
Switzerland	37.0	10 966	7.5	8 003	6.6
Germany	22.3	71 631	48.8	58 549	48.6
UK	10.3	4 670	3.2	4 233	3.5
France	-12.6	4 194	2.9	4 801	4.0
Italy	27.3	5 291	3.6	4 155	3.5
Benelux	7.4	10 541	7.2	9 812	8.2
Rest of Europe	37.7	15 905	10.9	11 548	9.6
North and South America	33.0	11 869	8.1	8 926	7.4
Middle and Far East	10.1	11 393	7.8	10 349	8.6
<b>Total</b>	<b>21.7</b>	<b>146 460</b>	<b>100.0</b>	<b>120 376</b>	<b>100.0</b>

Operating result		2010	Margin	2009	Margin
	Change in %	1 000 EUR	in %	1 000 EUR	in %
Operating result	54.6	26 940	18.4	17 428	14.5

Net operating assets		2010	Profitability	2009	Profitability
	Change in %	1 000 EUR	in %	1 000 EUR	in %
Net operating assets	5.2	60 310	44.7	57 348	30.4

Purchases of tangible assets		2010	2010	2009	2009
		1 000 EUR	in %	1 000 EUR	in %
Land and buildings		147	4.0	85	2.9
Machinery and equipment		2 217	59.7	1 727	59.5
Tools		651	17.5	850	29.3
Advance payments and construction in progress		698	18.8	239	8.3
<b>Total</b>		<b>3 713</b>	<b>100.0</b>	<b>2 901</b>	<b>100.0</b>

## ASSET AND CAPITAL STRUCTURE

A cautious approach to capital expenditure was adopted, with no construction projects undertaken. Most capital expenditure related to manufacturing equipment at the various production sites.

Due to the strong growth in result, the relatively low level of capital expenditure and an underproportional increase in operating net current assets, the return on capital employed (ROCE) climbed sharply to 44.7 % (previous year 30.4 %).

---

The operating result increased by 54.6 % to EUR 26.9 million thanks to encouraging growth in sales and rigorous cost-cutting measures implemented the previous year.

**26.9** MILLION EUR OPERATING RESULT

## EMPLOYEES

The annual average number of staff employed by the division rose by 7.4 % to 1 511. Most of this increase occurred at the production location in India. Per capital sales rose from EUR 85 000 to EUR 97 000.

PHOENIX MECANO ELCOM/EMS

# DOUBLING OF SALES IN PHOTOVOLTAICS AND STRONG SALES GROWTH IN ELECTROMECHANICAL COMPONENTS.

### Gross sales

in EUR million

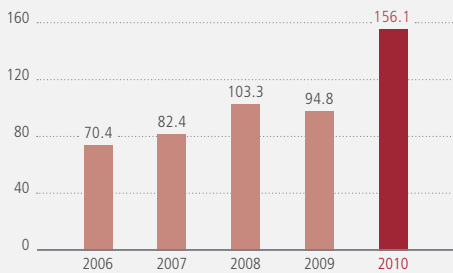

### Operating result and margin

in EUR million (— margin in %)

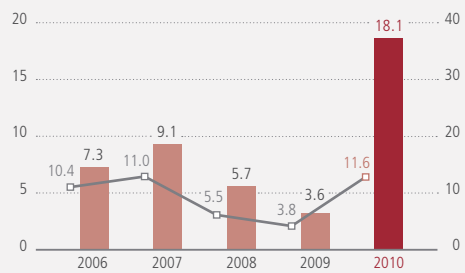

### Gross sales by region

in %

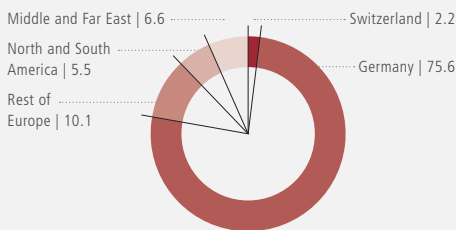

### Purchases of tangible assets

in %

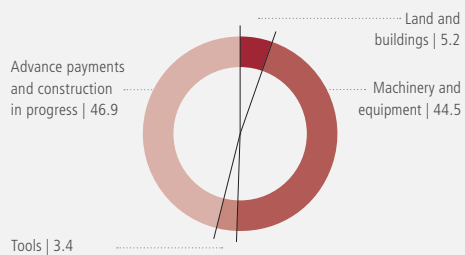



## OVERVIEW OF THE FINANCIAL YEAR

**In a generally favourable economic environment and a booming photovoltaics market, the division increased its sales by 64.6 % to EUR 156.1 million and saw its operating result increase fivefold to EUR 18.1 million. The operating margin topped the 10 % mark, with profitability at 20.3 %.**

## SALES AND PROFITABILITY

### Sales

The ELCOM/EMS division saw sales jump by 64.6 % in 2010, to EUR 156.1 million, with a minimal currency impact of 0.9 % and a consolidation impact of 1.3 %. Sales increases were achieved in all key markets. The strongest growth was recorded in its core market of Germany due to a rapid expansion of sales in the renewable energies and electromechanical components sectors.

Overall sales of electromechanical components (coding and micro-switches, terminal blocks, test probes) rose by 42.2 % in a positive market environment for industrial electronics. In the case of terminal blocks and test probes, this was assisted by an expansion of the product range.

The power quality products of Götz-Udo Hartmann and Datatel benefited heavily in Q2 and Q3 from the booming photovoltaic industry and increased their annual sales by 107 % to EUR 78.9 million. In Q4, demand for solar inverter chokes and transformers slowed and it is not yet clear how the photovoltaic market will develop from here. Some initial orders for instrument transformers were generated in the reporting year. Since May 2010, the Group's power quality products business has been bolstered by Lohse GmbH, Muggensturm (D), a leading manufacturer of special toroidal strip-wound cores, strip-wound cut cores and air-gap cores.

Sales in the electronic packaging business, represented by Hartmann Elektronik, WIENER Plein & Baus and Phoenix Mecano Digital Elektronik, were up by 24.9 % on the previous year, with substantial sales increases recorded in North America (+60.2 %). Some bottlenecks were experienced in the supply of components in this sector.

### Orders

Consolidated incoming orders for the ELCOM/EMS division totalled EUR 166.3 million in the reporting year, compared with EUR 98.7 million the previous year. This represents an increase of 68.6 %. The book-to-bill ratio (incoming orders as a percentage of gross sales) stood at 106.6 %.

### Result

The division's operating result increased fivefold from EUR 3.6 million to EUR 18.1 million. All major cost items develop under-proportionally to the dynamic growth in sales. The consolidation measures implemented in previous years also had a positive impact.

Gross sales by region		2010		2009	
		Sales	Share of sales	Sales	Share of sales
	Change in sales in %	1 000 EUR	in %	1 000 EUR	in %
Switzerland	36.6	3 419	2.2	2 503	2.6
Germany	71.2	118 206	75.6	69 061	72.8
UK	13.7	1 004	0.6	883	0.9
France	31.9	2 235	1.4	1 694	1.8
Italy	7.9	1 800	1.2	1 668	1.8
Benelux	55.8	1 069	0.8	686	0.8
Rest of Europe	43.9	9 581	6.1	6 660	7.0
North and South America	55.6	8 551	5.5	5 494	5.8
Middle and Far East	65.7	10 226	6.6	6 173	6.5
<b>Total</b>	<b>64.6</b>	<b>156 091</b>	<b>100.0</b>	<b>94 822</b>	<b>100.0</b>

Operating result		2010	Margin	2009	Margin
	Change in %	1 000 EUR	in %	1 000 EUR	in %
Operating result	400.5	18 148	11.6	3 626	3.8

Net operating result		2010	Profitability	2009	Profitability
	Change in %	1 000 EUR	in %	1 000 EUR	in %
Net operating result	81.9	89 589	20.3	49 247	7.4

Purchases of tangible assets		2010	2010	2009	2009
		1 000 EUR	in %	1 000 EUR	in %
Land and buildings		532	5.2	36	1.8
Machinery and equipment		4 555	44.5	1 282	62.4
Tools		352	3.4	194	9.4
Advance payments and construction in progress		4 792	46.9	541	26.4
<b>Total</b>		<b>10 231</b>	<b>100.0</b>	<b>2 053</b>	<b>100.0</b>

## ASSET AND CAPITAL STRUCTURE

Purchases of tangible assets rose from EUR 2.1 million to EUR 10.2 million in 2010. The sharp increase is mainly attributable to expansions in photovoltaic production. Most of the remaining capital expenditure was invested in replacements of production equipment.

Net operating assets increased by 81.9 % to EUR 89.6 million. This sharp rise is owing to three factors: the increased volume of capital expenditure, the assets acquired through the acquisition of Lohse GmbH and the increase in inventories. However, the return on capital employed (ROCE) climbed markedly by 12.9 percentage points to 20.3 %.

---

The division's operating result increased fivefold from EUR 3.6 million to EUR 18.1 million, driven by dynamic sales development and consolidation measures implemented in previous years.

**18.1** MILLION EUR OPERATING RESULT

## EMPLOYEES

The annual average number of staff employed by the division in the reporting year rose from 1 702 to 2 570. Most of this increase occurred at the production plants in Tunisia and Hungary. The division's per capita sales climbed from EUR 55 000 to EUR 61 000.

PHOENIX MECANO MECHANICAL COMPONENTS

# SUCCESSFUL INTEGRATION OF OKIN AND STRENGTHENING OF MARKET POSITION IN ASIA.

**Gross sales**

in EUR million

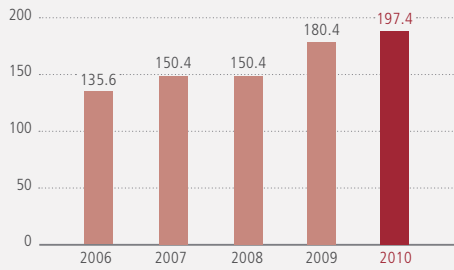

**Operating result and margin**

in EUR million (— margin in %)

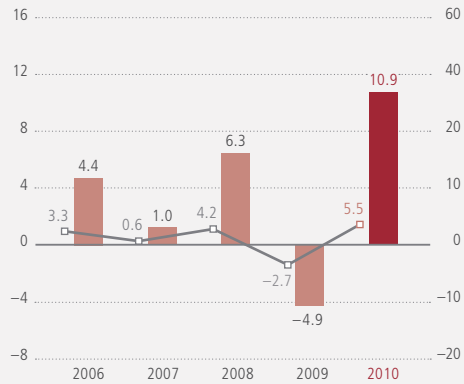

**Gross sales by region**

in %

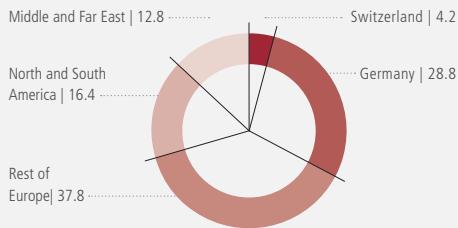

**Purchases of tangible assets**

in %

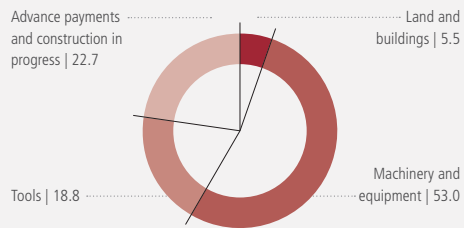

## OVERVIEW OF THE FINANCIAL YEAR

**The Mechanical Components division increased its sales by 9.5 % thanks to the recovery in the industrial sector and sales successes in overseas markets. Following the operating loss of the previous year, 2010 saw an operating profit of EUR 10.9 million. The investment in Okin Refined Electric Technology Co. Ltd. strengthened the division's market position in Asia.**

## SALES AND PROFITABILITY

### Sales

Sales rose by 9.5 % in the reporting year to EUR 197.4 million. Corrected for differences in foreign-exchange rates, the increase was 6.5 %. In organic terms, sales grew by 6.1 %. The overseas markets generated the biggest growth. In Europe, overall sales were up by 2.3 %, although the division's core market of Germany saw a drop of 6.6 %.

After a tentative start, the industrial components business largely made up for the sales losses incurred in 2009. Sales in the industrial assembly systems segment rose by 22.3 %.

The growth in linear adjustment and positioning systems for the capital goods market was even more dynamic, and customised solutions resulted in a number of project successes. The furniture and care sector was not as hard hit by the economic crisis as capital goods, and therefore experienced much less dynamic growth. In Europe, sales of linear drives for the furniture sector declined, although the division maintained its strong market position and there was an encouraging increase in sales of linear drives in the overseas markets. With effect from 22 November 2010, the Phoenix Mecano Group acquired a 90 % stake in the newly founded joint venture Okin Refined Electric Technology Co. Ltd., based in Jiaying City, China. The company will take over the development, production and sale of linear drives for the furniture and care industry in the Asian market and parts of the North American market. This move creates growth potential for the future. A new drive system was developed to enhance the office business; it will enter serial production in 2011. Overall sales of linear adjustment and positioning systems were up by 7.5 %.

### Orders

The division's incoming orders were up 5.0 % on the previous year, at EUR 200.3 million. The book-to-bill ratio (incoming orders as a percentage of gross sales) was 101.5 %.

### Result

2010 saw an operating profit of EUR 10.9 million, following an operating loss of EUR 4.9 million the previous year. The industrial components range became more profitable due to the implementation of efficiency improvement measures, particularly in distribution. Integration of the business areas of insolvent former competitor Okin, which the Group acquired in 2009, was largely completed in 2010. The cost-cutting measures implemented in 2009 in connection with the consolidation had a positive impact. In addition, a production site in Hungary was relinquished and part of the drive assembly operations relocated to Romania.

Gross sales by region		2010		2009	
		Sales	Share of sales	Sales	Share of sales
	Change in sales in %	1 000 EUR	in %	1 000 EUR	in %
Switzerland	37.8	8 275	4.2	6 005	3.3
Germany	-6.6	56 871	28.8	60 897	33.9
UK	-1.7	9 775	5.0	9 945	5.5
France	-1.7	16 014	8.1	16 291	9.0
Italy	32.4	7 751	3.9	5 853	3.2
Benelux	1.5	11 466	5.8	11 292	6.3
Rest of Europe	12.3	29 666	15.0	26 428	14.7
North and South America	27.9	32 416	16.4	25 338	14.0
Middle and Far East	37.6	25 185	12.8	18 303	10.1
<b>Total</b>	<b>9.5</b>	<b>197 419</b>	<b>100.0</b>	<b>180 352</b>	<b>100.0</b>

Operating result		2010	Margin	2009	Margin
	Change in %	1 000 EUR	in %	1 000 EUR	in %
Operating result	324.4	10 929	5.5	-4 871	-2.7

Net operating result		2010	Profitability	2009	Profitability
	Change in %	1 000 EUR	in %	1 000 EUR	in %
Net operating result	36.4	121 718	9.0	89 242	-5.5

Purchases of tangible assets		2010	2010	2009	2009
		1 000 EUR	in %	1 000 EUR	in %
Land and buildings		233	5.5	2 780	47.5
Machinery and equipment		2 243	53.0	1 766	30.2
Tools		797	18.8	691	11.8
Advance payments and construction in progress		963	22.7	616	10.5
<b>Total</b>		<b>4 236</b>	<b>100.0</b>	<b>5 853</b>	<b>100.0</b>

## ASSET AND CAPITAL STRUCTURE

Capital expenditure totalled EUR 4.2 million. In 2009, capital expenditure was EUR 5.9 million, including EUR 1.9 million for the construction of a new building in Stein am Rhein, Switzerland.

Net operating assets increased by 36.4 % to EUR 121.7 million. The rise was mainly due to the assets acquired in Okin Refined Electric Technology Co. Ltd. and an increase in inventories to improve supply capability. The return on capital employed (ROCE) was 9.0 %.

---

Thanks to increased profitability of the industrial components range and the successful integration of Okin, 2010 saw an operating profit of EUR 10.9 million, following an operating loss of EUR 4.9 million the previous year.

**10.9** MILLION EUR OPERATING RESULT

## EMPLOYEES

The annual average number of staff employed by the division was 1 808, up 252 on the previous year. This was due to an expansion of the workforce at the new production site in Romania and some staff overlaps in the relocation phase. Per capita sales fell by EUR 7 000 to EUR 109 000.

SHARE INFORMATION

# PROPOSED DIVIDEND FOR 2010: CHF 13.00. AN INCREASE OF 30 %.

Phoenix Mecano share price, 1 January 2006 – 31 December 2010, compared with the Vontobel Small Caps Index and SPI

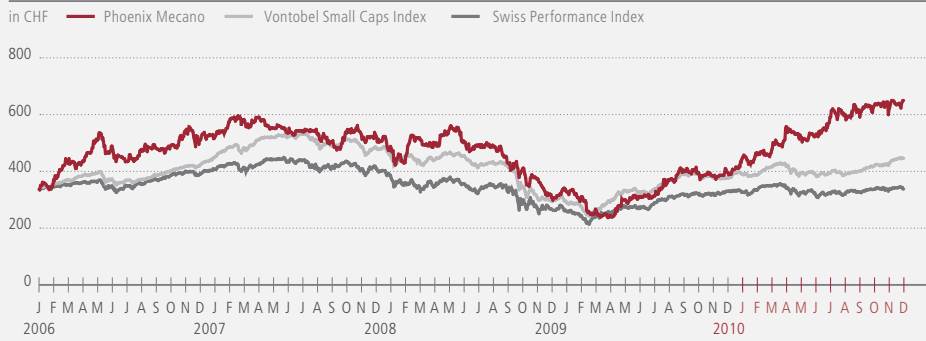

Monthly highs and lows in 2010 and average daily volume

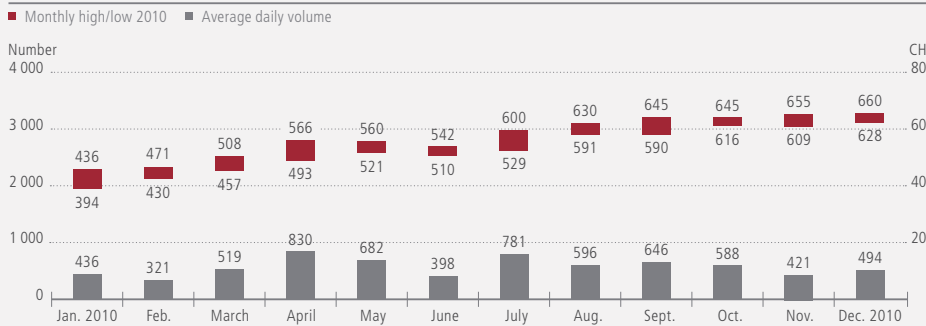



## PHOENIX MECANO ON THE STOCK EXCHANGE

Since its initial public offering in 1988, Phoenix Mecano has prioritised the interests of long-term investors. As has always been the case, all shares are bearer shares and there are no restrictions on ownership or voting rights. Capital that is not required for internal growth is returned to shareholders in the form of dividends, par value repayments and share buybacks.

## DIVIDEND POLICY AND SHARE INFORMATION

### Share capital

Phoenix Mecano AG's share capital of CHF 978 000 is divided up into 978 000 bearer shares with a par value of CHF 1.00 each. There are no restrictions on ownership or voting rights. The share capital has not been increased since the company went public in 1988. Phoenix Mecano AG's corporate policy dictates that growth should be funded out of the company's own capital resources.

### Share buyback programmes

Pursuant to a decision by the Shareholders' General Meeting of 28 May 2010, the remaining 10 000 shares from the 2008/2009 buyback programme were cancelled and the share capital reduced accordingly to 978 000 shares.

Year of buyback	Cancelled shares		Average repurchase price of cancelled shares	Shares outstanding
	Number	CHF	Number	Number
2005/2006	30 500	327.18		1 069 500
2007/2008	58 500	510.74		1 011 000
2008/2009	33 000	336.42		978 000

### Dividend payout and return of capital to shareholders

in million CHF ■ Proposed dividend ■ Share buyback

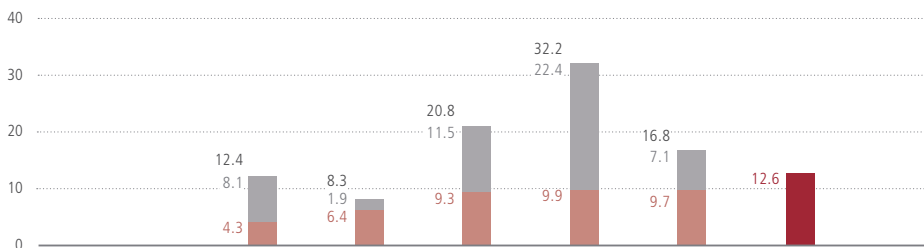

	2005	2006	2007	2008	2009	2010	Total
in million CHF							
Proposed dividend	4.3	6.4	9.3	9.9	9.7	12.6	52.2
Share buyback	8.1	1.9	11.5	22.4	7.1	–	51.0
<b>Total</b>	<b>12.4</b>	<b>8.3</b>	<b>20.8</b>	<b>32.3</b>	<b>16.8</b>	<b>12.6</b>	<b>103.2</b>

### Result of the period

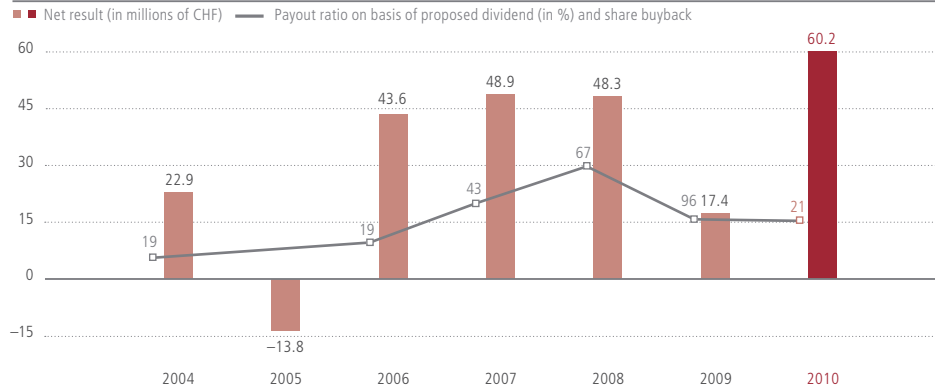

### Dividend policy and proposal

In view of the company's excellent future prospects, we will be raising the target range for dividend payouts from 15–25 % of sustainable result of the period to 20–30 %. The Board of Directors will propose to the Shareholders' General Meeting of 27 May 2011 that the dividend be increased from CHF 10.00 to CHF 13.00. This is an increase of 30 % compared with the previous year. The proposed dividend for financial year 2010 corresponds to around 21 % of the result of the period.

### Average trading volume in 2010

On average, 559 Phoenix Mecano shares were traded each day.

### Opting out

The company has not made any use of the possibility provided for in the Stock Exchange Act of excluding an acquiring company from the obligation to make a public purchase bid.

### Opting up

The limit for the obligation to make an offer pursuant to Article 32 of the Swiss Federal Law on Stock Exchanges and Securities Trade is 45 % of voting rights.

### Information for shareholders

<b>18 February 2011</b>	7:00 a.m.	Media release	› Provisional figures for financial year 2010
<b>27 April 2011</b>	7:00 a.m.	Media release	› Financial year 2010 › Q1 2011 › Publication of 2010 annual report
<b>27 April 2011</b>	9:30 a.m.	Media conference	› Financial year 2010 › Q1 2011
Widder Hotel Rennweg 7 8001 Zurich	11:30 a.m.	Financial analysts' conference	› Financial year 2010 › Q1 2011
<b>27 May 2011</b>	3:00 p.m.	Shareholders' General Meeting	
Hotel Klosterhof Oehningerstrasse 2 8260 Stein am Rhein			
<b>12 August 2011</b>	7:00 a.m.	Media release	› Half-yearly results 2011
<b>19 August 2011</b>	7:00 a.m.	Detailed report	› Half-yearly results 2011
<b>1 November 2011</b>	7:00 a.m.	Media release	› Q3 2011

## Share indicators at a glance

		2010	2009	2008	2007	2006
	Unit					
<b>Number of shares</b>						
Share capital <sup>1,2</sup> (bearer shares with a par value of CHF 1.00)	Number	978 000	988 000	1 069 500	1 069 500	1 069 500
Treasury shares	Number	5 459	19 202	79 930	31 432	1 955
Shares entitled to dividend <sup>3</sup>	Number	972 541	968 798	989 570	1 038 068	1 067 545
<b>Information per share</b>						
Operating result per share <sup>3</sup>	EUR	54.1	13.9	43.3	37.4	33.5
Result of the period per share <sup>3</sup>	EUR	45.1	12.0	30.9	28.9	26.0
Equity per share <sup>3</sup>	EUR	242.9	199.6	193.0	175.8	156.4
Free cash flow per share <sup>3</sup>	EUR	12.0	36.2	30.2	20.9	11.5
Dividend	CHF	13.00 <sup>6</sup>	10.00	10.00	9.00	6.00
<b>Share price</b>						
High	CHF	660	420	569	615	570
Low	CHF	404	235	300	474	360
Year-end price	CHF	660	394	317	530	534
<b>Share key figures</b>						
Dividend yield <sup>4</sup>	%	2.0	2.5	3.2	1.7	1.1
Payout ratio <sup>5</sup>	%	21	55	20	19	15
Price/profit ratio 31 December		10.6	21.8	6.5	11.2	13.0

<sup>1</sup> Pursuant to a decision by the Shareholders' General Meeting of 5 June 2009, the share capital was reduced by CHF 81 500 with effect from 28 September 2009 by cancelling 81 500 shares from the 2007/2008 and 2008/2009 share buyback programmes.

<sup>2</sup> Pursuant to a decision by the Shareholders' General Meeting of 28 May 2010, the share capital was reduced by CHF 10 000 with effect from 2 September 2010 by cancelling 10 000 shares from the 2008/2009 share buyback programme.

<sup>3</sup> Based on shares entitled to dividend as at 31 December.

<sup>4</sup> Dividend in relation to year-end price.

<sup>5</sup> Proposed dividend (shares entitled to dividend only) in relation to result of the period.

<sup>6</sup> Proposal to the Shareholders' General Meeting of 27 May 2011.

## Analyst coverage (as at 31 March 2011)

Our business performance is regularly monitored by the following analysts:

UBS AG	joern.iffert@ubs.com
Bank Vontobel	andreas.escher@vontobel.ch
Helvea	amigliorini@helvea.com
Zürcher Kantonalbank	richard.frei@zkb.ch

## Ticker symbols

Listing	SIX Swiss Exchange, Zurich
Securities No.	Inh. 218781
Reuters	PM.S
Bloomberg	PM SW Equity
Telekurs/Telerate	PM
ISIN	CH0002187810

## Further information for investors is available from

Benedikt A. Goldkamp, CEO  
 Phone +41 43 255 42 55  
 info@phoenix-mecano.com  
 www.phoenix-mecano.com/investor-relations.html

SUSTAINABILITY REPORT

# STRIKING A BALANCE BETWEEN ENVIRONMENTAL, SOCIAL AND ECONOMIC NEEDS.

**Employees by region**

in %

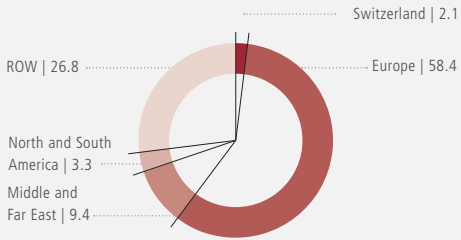

**Employees by division**

Number

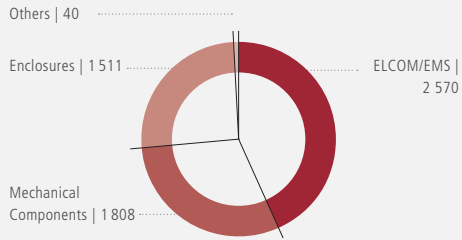

**Number of employees**

annual average

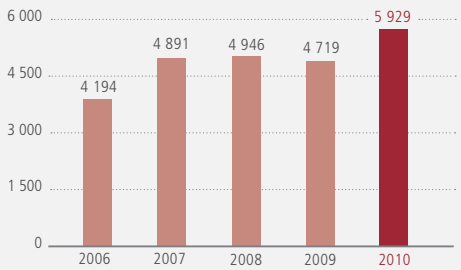

**Operating result per employee**

1 000 EUR

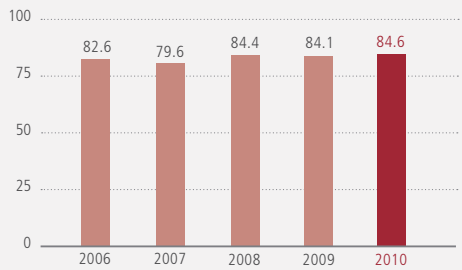

## SUSTAINABLE SUCCESS

The Phoenix Mecano Group's approach is based on environmental, social and economic aspects, fair and respectful cooperation that reaches across national borders and cultural boundaries, a long-term HR plan and strategic trainee development. The company's long-term, sustainable success takes priority over the maximisation of quarterly profits. This approach enables the Group to behave in a socially responsible and environmentally sensitive way, while its Code of Conduct ensures compliance with legislation and international rules and regulations.

## CODE OF CONDUCT

As a listed company with a global presence, Phoenix Mecano AG has a particular duty to abide by international legislation, regulations and guidelines. Failure to do so may harm the company's reputation and thereby adversely affect its share price, undermine the trust of customers, suppliers, business partners, authorities and the general public and consequently put jobs at risk over the long term. It was for this reason that the Group's Board of Directors and management introduced a Code of Conduct. The members of the Board of Directors and Executive Committee and the managing directors of the individual subsidiaries must act as role models and be seen to apply the principles contained in the Code of Conduct.

### Compliance with legislation, regulations and guidelines

Phoenix Mecano expects all Group employees to comply with applicable legislation and guidelines in their day-to-day work. The following internal regulations, among others, must also be observed:

#### Do's:

- › Compliance with anti-trust laws and competition and fair trading legislation
- › Transparent and legally-compliant accounting and financial reporting
- › Treating Phoenix Mecano Group property with respect

#### Don'ts:

- › Insider trading, and disseminating or exploiting insider information
- › Fraudulent activities
- › Unauthorised transfer of confidential data and documents
- › Bribery, corruption and donations to political parties
- › Accepting unreasonable financial benefits
- › Actions giving rise to conflicts of interest

All employees can report violations to their immediate superior or the next level of management, or, in case of doubt, directly to the Group's CEO. Major breaches will be punished appropriately: they may have disciplinary as well as legal consequences, and could even result in dismissal.

## SOCIAL RESPONSIBILITY

### **Employees as ambassadors**

The Phoenix Mecano Group believes that every person should be treated with respect, regardless of their gender, status, skin colour, religion or age. Cultural characteristics and differences between sites and subsidiaries are of course observed, and the company is committed to the protection of human rights, fair working conditions and equality.

In 2010, the Group employed around 5 929 staff on five continents. Its employees make a decisive contribution to the company's success. Many deal directly with customers and act as an interface with customers and partners. They are all ambassadors for the company. Each and every one has experience, knowledge and commitment of the kind needed to achieve set goals on a daily basis. In 2010, our dedicated staff with their indispensable expertise once again helped to ensure that our customary quality and reliability of production and service were maintained and further enhanced.

Phoenix Mecano provides a safe, motivating working environment and good working conditions. It goes without saying that the company remunerates its staff fairly and competitively, as well as paying bonuses and social security contributions. From its managerial staff, Phoenix Mecano expects social as well as technical skills: anyone occupying a leadership position must serve as a model, lead the way by setting a good example and ensure that the rights of all employees are protected.

The company encourages open communication – both internally and externally – and supports its employees in their personal commitments, provided these do not run counter to the company's interests. The Group offers its staff a range of continuing training opportunities as well as scope for internal career development. This helps to improve operational processes and the quality of products and services, as well as promoting safety at work and ultimately boosting employees' identification with 'their' company and group.

Through its transfer of knowledge and creation of new, challenging jobs, the company is helping to promote economic development in a wide range of countries. After a difficult 2009, in which some staff cuts were unavoidable, 2010 was a successful year, with employee numbers rising by 1 210 to a record high of 5 929. Many of the new staff were hired in the ELCOM/EMS division to meet surging demand in that part of the business.

### **Regional, social commitment**

In keeping with its mission statement and corporate structure, Phoenix Mecano gets involved in social projects at a regional level as and when required. For example, it supports a project for street children in Beijing, run by a former homeless man. The project operates as a boarding school, providing a home, food and clothing for up to 100 children aged between 6 and 13, who used to live on the streets. In India, the company is running a health programme to provide basic medical care, in conjunction with a hospital located near the company's premises.

## VISION

As a global player in the components sector, Phoenix Mecano develops detailed technical solutions with and for its customers. In our capacity as a specialised partner we meet our clientele's most stringent requirements with regard to technology, service and a customer-oriented approach, constantly assisting them by supplying anything from components to full systems.

## MISSION

Our success hangs on that of our customers. Close cooperation, constant communication and intensive exchanges of well targeted ideas are our main precepts. We support our customers as best as we can, making full use of our employees' know-how.

Phoenix Mecano is particularly committed to its shareholders. Since going public in 1988 on the Zurich stock exchange, the precursor of today's SIX, we have paid special attention to treating all our shareholders equally, implementing a clear dividend policy and pursuing a long-term refinancing and growth strategy.

We communicate openly with all interested parties and engage in regular contacts with the media and analysts. Any other information requirements are met via the Internet.

Our decentralised, market- and customer-oriented structure places high demands on our employees. We encourage them to adopt an entrepreneurial attitude, give them room for manoeuvre based on clear, agreed objectives, and reward their creation of lasting value.

## VALUES

Reliability vis-à-vis all interested parties is a prerequisite for credibility. Every day we work on putting these maxims into practice, with the management setting an example by fulfilling a responsible leadership function.

Naturally, the same also applies to the Board of Directors. Phoenix Mecano has recognised the importance of good corporate governance. This is only reflected to a minor extent in the information included in the annual report at the bidding of the SIX. Good corporate governance constitutes the basis for self-esteem and for the company's reputation, both internally and externally. In the first instance, good corporate governance has to be practised.

Ever since going public, Phoenix Mecano has cultivated the philosophy of shareholder value, based on the original, far-sighted definition of the term. In this respect nothing has changed where compliance with these maxims is concerned.

Profitability and growth are key requirements for maintaining competitiveness and value added and for creating new jobs both at home and abroad. We are constantly seeking potential for growth and greater efficiency. Recognised potential is immediately exploited in a bid to retain and enhance our market position and competitive edge.

The sustainability factor is underpinned by dealing thoughtfully with our natural resources. Phoenix Mecano is all in favour of corporate responsibility and, by using appropriate technologies and procedures, endeavours to strike the best possible balance between justified environmental, human and economic requirements.

## MISSION STATEMENT

### Market leadership

Phoenix Mecano has gained a leading position worldwide with its innovative products. Phoenix Mecano aims to maintain and extend the lead already attained.

### Scope

Phoenix Mecano operates at the interface between man and machinery. It has a reputation for distinctive solutions acknowledged by the market to set new trends.

### Initiative

It has a decentralised structure which facilitates quick decisions. It responds to market requirements, market changes and market opportunities before the competition. It strives to prevail over its rivals and over complacency within its own ranks.

### Growth

Phoenix Mecano is committed to steady growth while maintaining a solid financial foundation.

### Employees – key figures at a glance

		2010	2009	2008	2007	2006
Average/number unless otherwise indicated	Change 2009 to 2010					
<b>Personnel</b>	1 210	<b>5 929</b>	4 719	4 946	4 891	4 194
<b>By division</b>						
Enclosures	104	<b>1 511</b>	1 407	1 634	1 539	1 373
ELCOM/EMS	868	<b>2 570</b>	1 702	1 969	2 025	1 538
Mechanical Components	252	<b>1 808</b>	1 556	1 289	1 271	1 229
Others	-14	<b>40</b>	54	54	56	54
<b>By region</b>						
Switzerland	-2	<b>126</b>	128	142	142	137
Germany	70	<b>1 501</b>	1 431	1 522	1 455	1 305
Rest of Europe	428	<b>1 962</b>	1 534	1 375	1 375	1 332
North and South America	4	<b>196</b>	192	175	182	190
Middle and Far East	148	<b>554</b>	406	473	333	185
ROW	562	<b>1 590</b>	1 028	1 259	1 404	1 045
<b>Personnel expenses in EUR 1 000</b>	-2.3	<b>22.2</b>	24.5	24.2	22.9	24.8
<b>Gross sales per employee in EUR 1 000</b>	<b>0.5</b>	<b>84.6</b>	<b>84.1</b>	<b>84.4</b>	<b>79.6</b>	<b>82.6</b>

## ENVIRONMENTAL RESPONSIBILITY

### Recognised environmental maxims

Phoenix Mecano manufactures high-quality, state-of-the-art products using environmentally friendly technologies and processes that strike a balance between environmental, social and economic needs.

### Compliance with environmental standards

Phoenix Mecano promotes environmental responsibility and has a clear mission statement with associated operational goals. The company fosters a climate of openness and strives to engage in dialogue with employees and partners. All employees are regularly and comprehensively informed, trained and motivated to ensure that they implement the company's internal principles on environmental protection appropriately in their day-to-day work and comply fully with legal and regulatory requirements.

In all countries where Phoenix Mecano has operational or production facilities, in particular India and China, it has drawn up environmental protection standards based on the standards implemented in the EU, and Germany in particular. Regional regulations are also observed, and represent the minimum requirements adhered to. Phoenix Mecano continually documents progress and subjects itself to both internal and external audits.

In India, for example, emissions values for diesel-powered emergency generators above a certain size must be publicly displayed at the site entrance, and are also subject to inspection. In addition, rain water, particularly during the monsoon season, is captured and stored in under-



ground tanks, so as to reduce the use of mains water to almost zero. In India, Phoenix Mecano (India) certifies and audits local suppliers to ensure that they meet the required quality and social standards. In China, this task is performed by Shenzhen Elcom Trading Co. Ltd., a Phoenix Mecano subsidiary.

### **Quality and environmental management systems**

Phoenix Mecano's quality and environmental management systems have multiple ISO 9001 and ISO 14001 certifications. For example, Dewert Antriebs- und Systemtechnik, Okin Motion Technologies, PTR Messtechnik and Rose Systemtechnik use a sustainable environmental management system (EMS) based on DIN ISO 14001, which enables the planning, control, monitoring and improvement of all process-related environmental protection measures as well as environmentally-focused operations and personnel management. ISO 9001-certified quality management systems are also in place at Rose Systemtechnik, PTR Messtechnik, Datatel Elektronik, Rose + Krieger, Bopla and Hartmann Elektronik.

In Hungary, Phoenix Mecano Kecskemét Kft. operates in line with the ISO 9001:2000 quality management system and the ISO 14001:2004 environmental management system, thereby meeting quality and environmental objectives whilst ensuring maximum customer satisfaction. Phoenix Mecano (India) Ltd. and Phoenix Mecano S.E. Asia Pte Ltd. also have ISO 9001-certified quality management systems.

### **More transparency, more environmental protection**

Following the successful application of the European ROHS (Restriction of Hazardous Substances) Directive on the adoption of more environmentally friendly materials and production processes, Phoenix Mecano also successfully implemented another major project, namely REACH (Registration Evaluation Authorisation of Chemicals). REACH requires industrial companies like Phoenix Mecano, as 'downstream users', to have the chemicals used in their products and production processes classified and labelled, where usage exceeds 1 tonne a year, in order to better protect people and the environment in the European Union from the risks associated with the use of chemicals.

Application of these directives creates increased transparency and fosters a responsible approach to the handling of chemical substances. Where necessary, Phoenix Mecano has also published internal recommendations on safe handling and testing strategies. This gives end users greater certainty about what materials they are coming into contact with and any problems that these might pose.

## LOCAL VALUE CREATION

### **Decentralised structure ensures customer proximity**

The Phoenix Mecano Group has production facilities in most of the world's major economic regions. For the European market, the company manufactures in Switzerland, Germany, Eastern Europe and Tunisia. Short transport distances allow our products to reach end customers in a maximum of 48 hours, while also saving resources and reducing CO<sub>2</sub> emissions. In China, Phoenix Mecano manufactures products for the Asian markets and is expanding activities that are of increasing importance for this economic region. In India, too, the company pursues the same approach of local value creation. A welcome side-effect of this strategy is that local market requirements can be directly incorporated into the product development process.

## CORPORATE GOVERNANCE

# TRANSPARENT, RESPONSIBLE GOVERNANCE FOR LONG-TERM VALUE CREATION.

## Phoenix Mecano Group

Group headquarters	Finance and service companies	Segments	Production and sales companies
<b>Switzerland</b> Phoenix Mecano AG CH-8260 Stein am Rhein	Switzerland Channel Islands GB Germany The Netherlands	<b>Enclosures</b> Germany  <b>ELCOM/EMS</b> Germany  <b>Mechanical Components</b> Germany	Australia Austria Benelux Brazil France Germany Great Britain Hungary India Italy Korea (South Korea) People's Republic of China Romania Switzerland Singapore Scandinavia Spain Tunisia Turkey United Arab Emirates USA

## SUSTAINABLE CORPORATE POLICY

Phoenix Mecano is committed to transparency and responsibility in its corporate governance. It believes that sound, effective corporate governance is key to sustainable value creation. Informing shareholders, employees and all other interested parties in an open and comprehensive way promotes understanding and creates trust. The Phoenix Mecano Group's high level of transparency in communication enables all stakeholder groups to make a full and accurate assessment of business development and prospects and the sustainability of management and corporate policy.

The following pages deliberately follow the structural requirements of the SIX Swiss Exchange to make it easier for readers to seek specific information.

### Group structure and shareholders

Phoenix Mecano is a leading technology enterprise in the enclosures and industrial components sectors and has significant market shares in all international growth markets. It manufactures technical enclosures, electronics components, linear actuators and complete system integrations in three technical divisions. Its products are used principally but not exclusively in the machine industry, industrial electronics and the home and hospital care sector – its target markets. The Group is split into three divisions: Enclosures, ELCOM/EMS and Mechanical Components. Within these divisions, parent companies responsible for product management operate with the help of global production sites and sales companies. In Switzerland, Phoenix Mecano is present at two locations: Kloten, from where Phoenix Mecano Management AG runs the Group's operations, and Stein am Rhein, which is home to the headquarters of the Group's holding company as well as to Phoenix Mecano Komponenten AG, which distributes the various products manufactured by Phoenix Mecano subsidiaries in Switzerland, and the purchasing company Phoenix Mecano Trading AG. The Group's overall structure has always been very lean. Operational responsibility lies largely with the divisional managers and the managing directors of the individual subsidiaries, who are represented in the management (also referred to as the Executive Committee). The Group's operational structure is presented on pages 52/53. Detailed information about the scope of consolidation can be found on pages 79/80 of the financial report. None of the shareholdings is listed.

Significant shareholders	2010	2009
in %		
Planalto AG, Luxembourg	33.7	33.4
Tweedy, Browne Company LLC, New York	7.9*	7.9*
UBS Fund Management (Switzerland) AG, Basel	< 3.0	3.1
OppenheimerFunds Inc., New York of which 5.1 %** (previous year*) held by Oppenheimer International Growth Fund, New York	6.1	4.6*
Sarasin Investmentfonds AG, Basel	5.4*	5.4

This information is based on reports by the shareholders mentioned above.

\* Stake not reported in the year indicated. \*\* As reported on 10.11.2010.

Individual registrations can be viewed at the following link of the SIX Swiss Exchange:  
[www.six-exchange-regulation.com/publications/published\\_notifications/major\\_shareholders\\_de.html](http://www.six-exchange-regulation.com/publications/published_notifications/major_shareholders_de.html)

**Cross-ownership** There is no cross-ownership between the subsidiaries or between the subsidiaries and the parent company.

**Shareholders' agreements** There are no shareholders' agreements.

### Capital structure

**Capital/shares and participation certificates** As at 31 December 2010, Phoenix Mecano AG's share capital was fully paid up and consisted of 978 000 bearer shares (securities No. Inh. 218781; Reuters: PM.S; Telekurs/Telerate: PM) with a par value of CHF 1.00. All shares, apart from those owned by the company, fully entitle the bearer to vote and receive a dividend. As at the balance sheet date, the company owned 5 459 treasury bearer shares. There are no nominal shares and no participation or dividend-right certificates.

**Contingent and authorised capital** At present the Group has no contingent or authorised capital.

**Changes in capital** The Shareholders' General Meeting of 28 May 2010 approved the cancellation of 10 000 shares from the 2008/2009 buyback programme. The share capital was reduced from CHF 988 000 to CHF 978 000, with effect from 2 September 2010, and was then re-divided into 978 000 bearer shares with a par value of CHF 1.00 each. Pursuant to a decision by the Shareholders' General Meeting of 5 June 2009, 81 500 bought-back shares were cancelled from the 2007/2008 and 2008/2009 share buyback programmes and the share capital reduced from CHF 1 069 500 to CHF 988 000, with effect from 28 September 2009. No changes in capital took place in 2008 and 2007. Following a decision by the Shareholders' General Meeting of 26 May 2006, the share capital was reduced from CHF 1 100 000 to CHF 1 069 500 from 15 September 2006 by cancelling 30 500 shares from the 2005/2006 share buy-back programme.

**Limitations on transferability and nominee registrations** Since Phoenix Mecano has no nominal shares, there are no limits on transferability.

**Convertible bonds and options** There are no convertible bonds and no options.

### Board of Directors

The Board of Directors is the company's senior management body and comprises at least four members. The Board of Directors met four times in 2010.

**Elections and terms of office** Members of the Board of Directors are elected (or re-elected) by the Shareholders' General Meeting for a three-year term. To guarantee continuity within the Board of Directors, elections are (generally) staggered, with some members being re-elected and others newly recruited. If no shareholder requests separate voting, the members of the Board of Directors are elected in a single ballot. There are no restrictions on re-election. Members of the Board of Directors must be shareholders. Should non-shareholders be elected, they may only take up office after becoming shareholders, with shares being purchased via the stock exchange. The Board of Directors elects one of its members to become Chairman and also designates someone to take the minutes, who does not necessarily have to be a member of the Board of Directors.

**Powers** The powers of the Board of Directors are set out in the Swiss Code of Obligations as well as in Phoenix Mecano AG's Articles of Incorporation, which state that the Board of Directors is entitled to transfer the management or individual branches thereof and the representation of the company to one or more of its members or to third parties, pursuant to its own rules of procedure governing organisational matters. To this end it may set up committees, appoint, monitor or recall delegates or appoint a management comprising one or more of its own members or external persons. The Board of Directors determines the powers and obligations of committees, delegates, management and executives with a power of attorney.

The Board of Directors is authorised to take decisions provided that a majority of its members is present. Decisions are taken by a majority of votes cast by those present. In the event of a tie, the Chairman has the casting vote.

By law and pursuant to the company's Articles of Incorporation, the Board of Directors has the following main duties and powers:

- › Preparation of the proceedings of the Shareholders' General Meeting, especially the annual report, financial statements and proposals on the appropriation of earnings
- › Determination of corporate goals and the principles underlying corporate policy and strategy
- › Determination of the company's policy on risks
- › Decision-making regarding the establishment or cessation of major divisions of the company and authorisation of the acquisition or disposal of shareholdings, plus authorisation of any changes to the legal structure of the Group
- › Decision-making on the budget and medium-term planning (product and market strategy, financial and investment guidelines)
- › Allocation of signatory powers to members of the Board of Directors and determination of the principles governing signatures below that level
- › Determination of the principles of reporting to the Board of Directors, approval of the principles governing the company's finances and accounts and also internal and external audits.

**Other activities and vested interests** In keeping with the guidelines on corporate governance, the following activities and interests must be declared:

Mr Ulrich Hocker, Chairman of the Board of Directors, fulfils the following additional mandates:

Activities in governing and supervisory bodies

- › Deutsche Telekom AG, Bonn, Germany (Member of the Supervisory Board)
- › E.ON AG, Düsseldorf, Germany (Member of the Supervisory Board)
- › Feri Finance AG, Bad Homburg, Germany (Deputy Chairman of the Supervisory Board)
- › Gartmore SICAV, Luxembourg (Member of the Board of Directors)
- › Gildemeister AG, Bielefeld, Germany (Member of the Supervisory Board)

Permanent management and consultancy functions

- › Deutsche Schutzvereinigung für Wertpapierbesitz e.V. (DSW), Düsseldorf, Germany

Official functions and political posts

- › Member of the Stock Exchange Expert Committee of the Federal Ministry of Finance, Germany
- › Member of the Government Commission of the German Corporate Governance Code

Mr Beat Siegrist, Member of the Board of Directors, fulfils the following mandates:

Activities in governing and supervisory bodies

- › Essilor International, Charenton-le-Pont, France, (Member of the Executive Committee)
- › INFICON Holding AG, Bad Ragaz, Switzerland (Member of the Board of Directors)
- › Schweiter Technologies, Horgen, Switzerland (Member of the Board of Directors)

No other members of the Board of Directors have any relevant activities or vested interests to report.

**Cross-linkage** There is no cross-linkage. In other words, no member of the Phoenix Mecano Board of Directors serves on the Supervisory Board of a listed company of a fellow Director.



From left to right:  
Dr Florian Ernst  
Beat Siegrist  
Ulrich Hocker  
Benedikt A. Goldkamp  
Dr Martin Furrer

**As at 31 December 2010 the Board of Directors comprised the following members:**

**Ulrich Hocker (D)** Chairman of the Board of Directors since 2003. Member of the Board of Directors since 1988. Lawyer, Düsseldorf (Germany). Born 1950. Trained as a banker. Law degree, attorney at law. From 1985, manager at the Deutsche Schutzvereinigung für Wertpapierbesitz e.V. (DSW), Germany's largest shareholder organisation, and the publishing house Das Wertpapier. Chief Manager of the Deutsche Schutzvereinigung für Wertpapierbesitz e.V. since 1994.

**Benedikt A. Goldkamp (D)** Delegate of the Board of Directors. Member of the Board of Directors since 2000. Delegate of the Board of Directors since 1 July. CEO. Dipl. Finanzwirt, MBA Duke University, Lufingen (Switzerland). Born 1969. Gained a degree in financial consultancy, followed by a Master's in Business Administration. 1996–1997 Worked as an auditor and strategy consultant at McKinsey & Co. 1998–2000 Managed the Group's own production facility in Hungary and several Group-internal restructuring projects. Has been a member of the management and Board of Directors of Phoenix Mecano AG since 2000.

**Dr Florian Ernst (CH)** Member of the Board of Directors since 2003. Dipl. Wirtschaftsprüfer. Dr oec. HSG, Zollikon (Switzerland). Born 1966. Graduated as Dr oec. HSG in 1996. Qualified as an auditor in 1999. Worked as an auditor at Deloitte & Touche AG in Zurich until 1999. Then held various positions in the banking sector, including as a mergers & acquisitions consultant and the CFO of an alternative investment company in Pfäffikon, Schwyz. Since 2008 he has been working for Deutsche Bank in Zurich in the field of private equity.

**Dr Martin Furrer (CH)** Member of the Board of Directors since 2003. Lawyer. Dr iur., MBA INSEAD, Zumikon (Switzerland). Born 1965, gained a doctorate in law (Dr iur.) from Zurich University, then an MBA from INSEAD in Fontainebleau, and passed the bar examination of the Canton of Zurich. Started out as a lawyer for Baker & McKenzie in Sydney, then became a strategy consultant for McKinsey & Co. in Zurich. Has been back working as a lawyer for Baker & McKenzie in Zurich since 1997, specialising in private equity, mergers & acquisitions, capital market law and restructuring. Has been a partner at Baker & McKenzie since 2002.

**Beat Siegrist (CH)** Member of the Board of Directors since 2003. President of the Satisloh Group and Member of the Executive Committee at Essilor, Paris and of the Board of Directors at Schweiter Technologies, Horgen. Dipl. Ing. ETH, MBA Fontainebleau, Herrliberg (Switzerland). Born 1960, gained the following qualifications: Dipl. Ing. ETH 1985, MBA Fontainebleau and McKinsey Fellowship 1988. Development engineer for data transfer with Contraves, Senior Consultant and Project Manager at McKinsey & Co. responsible for reorganisations and turnaround projects in the machine industry. CEO of Schweiter Technologies, Horgen, from 1996 to 2008. Since 2008 has been Managing Director of the Satisloh Group and a Member of the Executive Committee at Essilor, the world's largest manufacturer of ophthalmic lenses, with sales of CHF 5 billion.

**Internal organisational structure** The Board of Directors is deliberately kept small and usually performs its duties collectively. The Audit Committee first set up in 2003 is primarily responsible for monitoring external audits. In that task it is supported by the Internal Auditing Department. The Audit Committee is chaired by Dr Florian Ernst in his capacity as a non-executive member of the Board of Directors. Dr Ernst is a certified auditor and has the necessary knowledge and experience of finance and accounting. Another member of the Audit Committee is the Chairman of the Board of Directors, Ulrich Hocker. The CEO and CFO also attend Audit Committee meetings. The Committee held two three-hour meetings in 2010.

The Audit Committee works in an advisory capacity and prepares draft resolutions and recommendations for the attention of all members of the Board of Directors. Decisions are taken by the whole Board of Directors.

**Information and control instruments vis-à-vis the management (Executive Committee)**

The Board of Directors has a number of instruments to enable it to perform its duties vis-à-vis the management to the fullest extent. For example, the company has a management information system encompassing all Phoenix Mecano Group companies, which enables it to obtain a quick and reliable picture of the income and assets of the Group, divisions or individual companies at any time. Reporting takes place monthly. Regular meetings with members of the Executive Committee ensure that Board members are fully informed and have a sound basis for decision-making.

In 2002, a Group-wide risk management system and dedicated, full-time Internal Auditing Department were set up. The latter is accountable to the Board of Directors and reports directly to it. Both institutions proved invaluable and were duly developed further. A quality assessment conducted by an external auditor (KPMG AG) in late 2006 confirmed that the Phoenix Mecano Group's Internal Auditing Department complied with international standards. A quality assessment is carried out every five years. Key audit issues in 2010 were the internal control system as well as accounts receivable and inventory management and construction investments.

**Members of the Board of Directors**

Name	Function	On the Board since	In current position since	Term expires in	Operational management tasks
Ulrich Hocker	Chairman Member of the Audit Committee	1988	2003	2012	No
Benedikt A. Goldkamp	Delegate	2000	2001	2012	Yes
Dr Florian Ernst	Member Chairman of the Audit Committee	2003	2003	2012	No
Dr Martin Furrer	Member	2003	2003	2012	No
Beat Siegrist	Member	2003	2003	2012	No



## Management

The management comprises the Delegate of the Board of Directors and the company's heads of division. It is chaired by the Delegate of the Board of Directors. The management aids the Delegate by coordinating the Group's companies and discusses matters affecting more than one division of the company.

**Other activities and vested interests** The members of the management do not perform any duties in governing or supervisory bodies of any major Swiss or foreign corporate bodies, institutions or foundations, nor do they fulfil any management or consultancy functions on a permanent basis.

**Management contracts** Furthermore, there are no management contracts between the Group and companies or persons with management duties.

Further management information see pages 48 and 49.

## Remuneration, shareholdings and loans

**Content and method of determining compensation** The compensation of members of the Board of Directors, except for the Delegate of the Board of Directors, is set out in Article 18 of the Articles of Incorporation. This states that, in return for their work, the members of the Board of Directors shall receive a fixed compensation independent of retained earnings. This is paid annually in cash after the Shareholders' General Meeting. The remuneration paid to the members of the Board of Directors is assessed by the Chairman and Delegate of the Board of Directors. The compensation is reviewed annually and adjusted as necessary.

All components of the compensation of the Delegate of the Board of Directors are decided on annually by the Chairman of the Board of Directors. The Delegate of the Board of Directors determines the compensation of the Executive Committee annually.

The Delegate of the Board of Directors and the members of the Executive Committee (management) are paid in accordance with their individual employment contracts. The compensation comprises a fixed remuneration (including benefits in kind) and a variable remuneration, as well as social security and pension payments. The fixed remuneration is determined based on job profile, qualifications and market conditions. The annual variable compensation level for members of the Executive Committee, except the CEO, COO and CFO, is determined based on income and return on capital targets, the basic features of which are as follows: the return on capital targets are derived from the weighted average costs of capital (WACC), which also correspond to the required minimum return on new projects and investments in the Phoenix Mecano Group. For these Executive Committee members, variable remuneration is capped at 140 % of the target bonus. There is no penalty system. Typically, a total of 80 % to 90 % of the variable remuneration components are based on quantitative targets, half relating to income (EBIT) and half to return on capital employed (ROCE). 10 % to 20 % are based on personal, qualitative targets, set annually by the Delegate of the Board of Directors. For the CEO, COO and CFO, the variable compensation is based on the Group's result of the period less a minimum return on equity. Variable remuneration typically accounts for between 20 % and 50 % of the total, and in some cases may exceed this. In 2009, this model was expanded to include a long-term component. Under the new system, variable remuneration for Executive Committee members, excluding the CEO, COO and CFO, over a three-year period will only be paid if the respective division's return on capital employed (ROCE) is higher than 15 % (12 % in some cases).

If this minimum rate of return is not achieved within a three-year period, the entitlement to variable remuneration is lost without substitution.

There is no provision for severance pay for serving members of the Board of Directors and Executive Committee.

There are no participation programmes for members of the Board of Directors and/or the Executive Committee. Accordingly, during the year under review no shares, convertible loans, options, participation certificates or such like were issued or awarded to members of the Board of Directors, management or employees.

Neither external consultants nor benchmark studies are consulted when setting compensation.

Total compensation of serving members of the Group's bodies over two years:

Remuneration of serving members of the Group's bodies	2010	2009
1 000 EUR		
Chairman of the Board of Directors	95	86
Delegate of the Board of Directors	806	385
Other members of the Board of Directors	93	85
<b>Remuneration of the Board of Directors</b>	<b>994</b>	<b>556</b>
<b>Remuneration of the Executive Committee</b> (excluding the Delegate of the Board of Directors)	<b>2 209</b>	<b>1 663</b>
<b>Remuneration of the Board of Directors and the Executive Committee</b>	<b>3 203</b>	<b>2 219</b>
Social security contributions	200	159
Pension payments	207	187
<b>Total remuneration of the Board of Directors and the Executive Committee</b>	<b>3 610</b>	<b>2 565</b>

More information can be found in the Phoenix Mecano AG Financial Report on page 127.

**Compensation of former members of the Group's bodies** The Phoenix Mecano Group's consolidated statement of income for 2010 includes no compensation for former members of the Group's bodies who left in the preceding period or before.

**Share allocations during the reporting year** No shares were allocated.

**Options** No options were organised.

**Additional fees and allowances** No additional fees or allowances were owed or paid out to members of the Group's bodies or persons related to them.

**Loans to corporate officers** No loans were made to corporate officers.

**Highest total compensation** The highest total compensation is listed in the section entitled "Remuneration of serving members of the Group's bodies" (see table above; further information can be found in the Phoenix Mecano AG Financial Report on page 128).

Share ownership		31 Dec. 2010	31 Dec. 2009
Ulrich Hocker	Chairman	8 654	8 624
Benedikt A. Goldkamp	Delegate	1 845	1 820
Dr Florian Ernst	Member	10	10
Dr Martin Furrer	Member	100	100
Beat Siegrist	Member	400	400
<b>Shares held by the Board of Directors</b>		<b>11 009</b>	<b>10 954</b>
Ralph Gamper	Member	180	330
Maximilian Kleinle	Member	0	50
Dr Joachim Metzger	Member	55	91
René Schäffeler	Member	80	80
<b>Shares held by the Executive Committee</b>		<b>315</b>	<b>551</b>

### Shareholders' participation

**Voting rights and proxy voting** One share entitles the holder to one vote at the Shareholders' General Meeting. There is no restriction on voting rights.

Shareholders may also exercise their voting rights by transferring their mandate in writing to another shareholder. Natural persons may not be legally represented by non-shareholders.

**Statutory quorums** Unless the law or the company's Articles of Incorporation stipulate that decisions be taken by a qualified majority, the Shareholders' General Meeting takes decisions by means of an absolute majority of the votes cast, irrespective of the number of shareholders present or the number of votes. In the event of a tie, the Chairman has the casting vote, except in elections, where the final decision will be taken by lots if need be.

The adoption and amendment of the Articles of Incorporation and any decisions entailing an amendment of the Articles of Incorporation must be approved by three quarters of the votes cast, irrespective of the number of shareholders present or the number of votes.

### Convocation of the Shareholders' General Meeting/Inclusion of items on the agenda

The Shareholders' General Meeting (GM), the company's top body, is headed by the Chairman. Invitations to the GM are issued at least 20 days in advance of the meeting by means of a single announcement in the company's publications. The invitation must contain the agenda of the meeting and the proposals by the Board of Directors and shareholders who called for the convocation of a Shareholders' General Meeting or the inclusion of an item on the agenda. Pursuant to a decision taken by the GM of 7 June 2002, shareholders representing shares with a par value of CHF 100 000 may demand the inclusion of an item on the agenda.

**Shareholders' rights** All shareholders are entitled to attend the Shareholders' General Meeting. To participate and make use of their rights to vote and submit proposals, they must demonstrate their share ownership.

**Inscriptions into the share register** Since Phoenix Mecano only has bearer shares, no share register is kept.



From left to right:  
Philip J. Brown  
Dr Rochus Kobler (sitting)  
Dieter B. Schaadt  
Ralph Gamper  
Benedikt A. Goldkamp  
Dr Joachim Metzger (sitting)  
Maximilian Kleinle  
René Schäffeler

**As at 31 December 2010, the management comprised the following members:**

**Benedikt A. Goldkamp (D)** Delegate of the Board of Directors/CEO. Dipl. Finanzwirt, MBA. Lufingen (Switzerland). See under Board of Directors on page 43 of this report.

**Philip J. Brown (GB)** Member of the Executive Committee since 2007. Incorporated Engineer (IEng). MBA. Frederick (MD, USA). Born 1961. Worked for eleven years as chief engineer in the British navy. From 1988 he occupied a variety of posts, most recently as managing director of the UK subsidiary of a global industrial controls manufacturer. He was Managing Director of Phoenix Mecano UK between 1997 and 2005 and has been President and CEO of Phoenix Mecano (USA) since 2005. Since 2009 President and CEO of Okin America Inc. (USA).

**Ralph Gamper (CH)** Member of the Executive Committee since 2006. Machine technician, Schlattingen (Switzerland). Born 1955. Started his career as a technical draughtsman, gained his Matura (Swiss university entrance qualification), then qualified as a machine technician, sales manager and business manager. Since 1982 Ralph Gamper has been in the employ of Phoenix Mecano Komponenten AG, Stein am Rhein, which covers the Swiss market for the entire Phoenix Mecano Group.

**Maximilian Kleinle (D)** Member of the Executive Committee since 2004. Dipl. Ing. (FH), Baar (Switzerland). Born 1961. Graduated from college as an electrical engineer, then added an MBA. 1990–1996 Various management posts in distribution and marketing of technical products. 1997–2003 CEO of a company in precision engineering and electronics. He was General Manager of the ELCOM/EMS division from October 2003 to January 2009. Since February 2009 he has been head of the Dewert/Okin business area (Mechanical Components division).

**Dr Rochus Kobler (CH)** COO/Member of the Executive Committee since 2010. Dr oec. HSG, Dipl. Ing. ETH/MSc, Unterägeri (Switzerland). Born 1969. From 1997 to 2002 he was Senior Engagement Manager at McKinsey in Zurich, Johannesburg and Chicago. Between 2002 and 2010 he served as CEO and Member of the Board of Directors at the international production and trading group Gutta. He has been COO since 1 September 2010, with responsibility for the operational management of the Phoenix Mecano Group.

**Dr Joachim Metzger (D)** Member of the Executive Committee since 1992. Qualified mechanical and industrial engineer. Dr rer. pol., Rimbach (Germany). Born 1951. Worked for several years for Arthur Andersen as an auditor and management consultant. Became a Head of Division and Head of Materials Management at AMP as a member of the Executive Committee. 1989–1992 Managing Director at Rose + Krieger, 1992–1993 Managing Director at Dewert. Since 1992 he has been a director in charge of Business Development (global sourcing and opening up new markets in China, India, Southeast Asia and South America).

**Dieter B. Schaadt (D)** Member of the Executive Committee since 1991. Technician, Minden (Germany). Born 1945. Trained as a power electrician and technician. Has been at Rose Systemtechnik since 1976. There he was sales and marketing manager from 1976–1986 and has been Managing Director since 1986. Since 1991 he has been head of the Enclosures division. Runs European subsidiaries of the Group in the UK, France, Belgium, the Netherlands, Italy and Austria.

**René Schäffeler (CH)** CFO/Member of the Executive Committee since 2000. Certified accountant/controller, Stein am Rhein (Switzerland). Born 1966. Commercial training and active for several years in the banking sector. Has been at Phoenix Mecano since 1989. After serving as Controller (until 1991), Head of the Group Accounting Department (1992–1996) and Deputy Director of Finances and Controlling (1997–2000), he has been an executive director and CFO since 2000. In this post he is responsible for finances, group accounting, controlling and taxes.

### Changes of control and defence measures

**Duty to make an offer** The limit for the obligation to make an offer pursuant to Article 32 of the Swiss Federal Law on Stock Exchange and Securities Trade is 45 % of the voting rights ('opting up'). Under the Swiss Stock Exchange Act, a potential acquiring company may be exempted from the obligation to make a public purchase bid ('opting out'). Phoenix Mecano has not made use of this possibility.

**Clauses on changes of control** Phoenix Mecano does not have any change-of-control clauses, nor are there any agreements about contract extensions or severance payments in the event of a hostile takeover.

### Statutory auditors

**Duration of the mandate and term of office of the auditor in charge** By a decision of the Shareholders' General Meeting of 28 May 2010, KPMG AG, Zurich, were appointed as statutory auditors for the accounting and financial statements of Phoenix Mecano AG and as Group auditors of the consolidated financial statements of the Phoenix Mecano Group for a period of one year. KPMG AG, Zurich, first assumed the mandate as statutory and Group auditors in 2006; the auditor in charge, Mr Roger Neining, has also been in office since the 2006 Shareholders' General Meeting. The auditor in charge is replaced every seven years.

**Auditors' fees** In the reporting year, KPMG received fees totalling EUR 784 000 for auditing the financial statements and consolidated financial statements.

**Additional fees** KPMG received additional fees of EUR 640 000 in the reporting year: EUR 616 000 for tax consultancy and EUR 24 000 for legal advice and auditing of the capital decrease.

**Audit supervision and control instruments** Phoenix Mecano has a dedicated full-time Internal Auditing Department and a Board of Directors' Audit Committee. The external auditors attended both Audit Committee meetings in the reporting year. They inform the Audit Committee, both orally and in writing, of the outcome of the Group audit and the audit of the financial statements of Phoenix Mecano AG. Specific observations relating to the audit are presented to the Board of Directors in the form of a comprehensive report.

The Audit Committee assesses the statutory auditors' performance annually based on the documents, reports and presentations they produce and the relevance and objectivity of their observations. In so doing, the Committee also takes into account the opinion of the CFO. The amount of the statutory auditors' fees is regularly reviewed and compared with the auditing fees of other industrial companies. It is negotiated by the CFO and approved by the Audit Committee. All services performed outside the scope of the statutory audit mandate are compatible with the audit duties.

Auditors' fees/additional fees	2010	2009
1 000 EUR		
<b>Total auditor' fees</b>	<b>784</b>	<b>762</b>
Tax consultancy	616	256
Legal advice and auditing of the capital decrease	24	17
<b>Total additional fees</b>	<b>640</b>	<b>273</b>
<b>Total</b>	<b>1 424</b>	<b>1 035</b>

**Information policy**

Phoenix Mecano's senior officers, namely the Board of Directors and management, are committed to open information and communication both within the Group and externally, believing that transparency alone creates trust. As well as attending official information events:

- › the balance sheet press conference
- › the financial analysts' meeting
- › the Shareholders' General Meeting

the company's representatives are in regular contact with media representatives, financial analysts and investors.

The calendar of events and publications, along with contact details for the Investor Relations Manager, can be found in the "Share Information" section on pages 30 to 31. Extensive information is also available on the Internet at [www.phoenix-mecano.com](http://www.phoenix-mecano.com), from where the annual report and up-to-date media information can be downloaded. It goes without saying that interested parties can also obtain information about other strategic, market-related or financial aspects of the Group's activities. Ad hoc disclosures are published on the following pages:

- › Pull link: <http://www.phoenix-mecano.com/current-media-releases.html>
- › Push link: <http://www.phoenix-mecano.com/subscribe.html>

Print media announcements are published in the Swiss Official Gazette of Commerce (SOGC) as well as a number of major daily newspapers in German-speaking Switzerland.

# GROUP OPERATIONAL STRUCTURE

## Group headquarters

**Switzerland**  
Phoenix Mecano AG  
CH-8260 Stein am Rhein

## Finance and service companies

**Switzerland**  
Phoenix Mecano Management AG  
CH-8302 Kloten  
Managing directors:  
B. A. Goldkamp, R. Schäffeler

**Phoenix Mecano Trading AG**  
CH-8260 Stein am Rhein  
Managing director:  
Dr J. Metzger

**Channel Islands GB**  
Phoenix Mecano Finance Ltd.  
St. Helier  
Jersey, Channel Islands  
Managing director:  
H. Durell

**Germany**  
IFINA Beteiligungsgesellschaft mbH  
D-32457 Porta Westfalica  
Managing directors:  
B. A. Goldkamp, D. B. Schaadt,  
M. Sochor, M. Kleinle

**The Netherlands**  
PM International B.V.  
NL-7005 AG Doetinchem  
Managing directors:  
G. H. B. Hartman, B. A. Goldkamp,  
R. Schäffeler

## Enclosures

D. B. Schaadt

**Germany**  
**Bopla Gehäuse Systeme GmbH**  
D-32257 Bünde  
Managing director:  
R. Bokämper

**Kundisch GmbH + Co. KG**  
D-78056 Villingen-Schwenningen  
Managing director:  
H. Hartmann

**Rose Systemtechnik GmbH**  
D-32457 Porta Westfalica  
Managing director:  
D. B. Schaadt

## ELCOM/EMS

B. A. Goldkamp

**Germany**  
**Datatel Elektronik GmbH**  
D-30853 Langenhagen  
Managing directors:  
B. A. Goldkamp, K. H. Goos

**Götz-Udo Hartmann GmbH + Co. KG**  
D-61279 Grävenwiesbach  
Managing directors:  
B. A. Goldkamp, K. H. Goos

**Hartmann Codier GmbH**  
D-91083 Baiersdorf  
Managing directors:  
B. A. Goldkamp, P. Scherer

**Hartmann Elektronik GmbH**  
D-70499 Stuttgart (Weilimdorf)  
Managing directors:  
Dr G. Zahnenbenz, W. Fritz

**Phoenix Mecano Digital Elektronik GmbH**  
D-99848 Wutha-Farnroda  
Managing director:  
R. Bormet

**Plein & Baus GmbH**  
D-51399 Burscheid  
Managing directors:  
A. Köster, Dr G. Zahnenbenz

**PTR Messtechnik GmbH + Co. KG**  
D-59368 Werne  
Managing directors:  
B. A. Goldkamp, P. Scherer



**Mechanical Components****B. A. Goldkamp****Germany****Dewert Antriebs- und Systemtechnik GmbH**

D-32278 Kirchlegern

Managing directors:

Dr J. Gross, M. Kersting, M. Klimmek,

A. Roither

**Okin Motion Technologies GmbH**

D-51429 Bergisch Gladbach

Managing directors:

B. A. Goldkamp, Dr J. Gross, M. Kleinle

**RK Rose + Krieger GmbH**

D-32423 Minden

Managing director:

H. Hoffmann

**Production and sales companies****Australia****Phoenix Mecano Australia Pty Ltd.**

Tullamarine, VIC 3043, Australia

Managing directors:

S. J. Gleeson, T. Thuess

**Austria****AVS Phoenix Mecano GmbH**

A-1230 Vienna

Managing director:

R. Kleinrath

**Benelux****PM Komponenten B.V.**

NL-7005 AG Doetinchem

Managing director:

G. H. B. Hartman

**PM Komponenten N.V.**

B-9800 Deinze

Managing director:

M. Lutin

**Brazil****Phoenix Mecano Comercial e Técnica Ltda.**

São Paulo

Managing director:

D. Weber

**France****Phoenix Mecano S.à.r.l.**

F-94121 Fontenay sur Bois, Cedex

Managing director:

J. P. Schreiber

**Germany****Lohse GmbH**

D-76461 Muggensturm

Managing directors:

O. Lohse, K. H. Goos

**RK Rose + Krieger GmbH****System- & Lineartechnik**

D-88697 Bermatingen

Managing director:

M. Pelz

**RK Schmidt Systemtechnik GmbH**

D-66647 Marpingen-Alsweiler

Managing director:

J. U. Schmidt

**Rose Gehäusetechnik GmbH**

D-16227 Eberswalde Finow

Managing director:

L. Waltl

**Great Britain****Phoenix Mecano Ltd.**

GB-Aylesbury, HP 198 TX

Managing director:

D. B. Schaadt

**Hungary****Phoenix Mecano Kecskemét Kft.**

H-6000 Kecskemét

Managing directors:

Dr Z. Nagy, Ch. Porde

**India****Phoenix Mecano (India) Ltd.**

Dist. Pune 412108

Managing director:

S. Shukla

**Italy****Phoenix Mecano S.r.l.**

I-20065 Inzago (Milan)

Managing director:

D. B. Schaadt

**Korea (South Korea)****Phoenix Mecano Korea Co. Ltd.**

Seoul 153-863

Managing director:

T. J. Ou

**People's Republic of China****Okin Refined Electric Technology Co. Ltd.**

Jiaxing 314024

Managing directors:

Dr J. Gross, J. Tang

**Mecano Components (Shanghai) Co. Ltd.**

Shanghai 201802

Managing director:

K. W. Phoon

**Phoenix Mecano Hong Kong Ltd.**

Hong Kong

Managing directors:

M. Kleinle, R. Schöffeler

**Shenzhen Elcom Trading Co. Ltd.**

Shenzhen

Managing director:

P. Scherer

**Romania****Phoenix Mecano Plastic S.r.l.**

RO-550052 Sibiu

Managing director:

C. Marinescu

**Singapore****Phoenix Mecano S.E. Asia Pte Ltd.**

Singapore 408863

Managing director:

T. J. Ou

**Scandinavia****Okin Scandinavia AB**

S-360 44 Ingelstad

Managing director:

P. Nilsson

**Phoenix Mecano ApS**

DK-5220 Odense SØ

Managing director:

R. Davidsen

**Spain****Sistemas Phoenix Mecano****España S.A.**

E-50011 Zaragoza

Managing director:

C. Aranda-Hutchinson

**Switzerland****Phoenix Mecano Komponenten AG**

CH-8260 Stein am Rhein

Managing director:

R. Gamper

**Tunisia****Phoenix Mecano Hartu S.à.r.l.**

TN-2013 Ben Arous

Managing director:

Dr H. Oweinah

**Phoenix Mecano Digital Tunisie S.à.r.l.**

TN-2084 Borj-Cedria

Managing director:

R. Bormet

**Phoenix Mecano ELCOM S.à.r.l.**

TN-1100 Djebel El Ouest-Zaghouan

Managing director:

Dr H. Oweinah

**Turkey****Phoenix Mecano Mazaka****Endüstriyel Ürünler San ve Tic AŞ**

İvedik OSB 1434. St. No:5

TR-06374 Yenimahalle/Ankara

Managing directors:

Y. Eren, B. Cihangiroglu

**United Arab Emirates****Rose Systemtechnik Middle East (FZE)**

125M2 Warehouse, Sharjah

Managing director:

H. Felsmann

**USA****Okin America Inc.**

Shannon, Mississippi 38868

Managing director:

P. Brown

**Phoenix Mecano Inc.**

Frederick, Maryland 21701

Managing director:

P. Brown

**WIENER Plein & Baus Corp.**

Springfield, Ohio 45505

Managing director:

A. Ruben

## INFORMATION ON THE FINANCIAL STATEMENTS

2010 SAW PHOENIX MECANO RETURN TO THE GROWTH TRAJECTORY OF 2007 AND 2008 AND SUBSTANTIALLY INCREASE ITS SALES AND PROFIT. THE IMPROVED GLOBAL ECONOMY AND THE EXCEPTIONAL DYNAMISM OF THE EMERGING MARKETS OFFER PHOENIX MECANO EXCELLENT DEVELOPMENT OPPORTUNITIES IN THE COMING YEARS.

GLOBAL. FLEXIBLE. DYNAMIC.

### **54 PHOENIX MECANO GROUP FINANCIAL REPORT 2010**

56 Consolidated balance sheet 58 Consolidated statement of income 59 Consolidated statement of comprehensive income 60 Consolidated statement of cash flow 62 Consolidated statement of changes in equity 64 Consolidated segment information 66 Notes to the consolidated financial statements 117 Report of the statutory auditor on the consolidated financial statements 119 Five-year overview

In a substantially improved market environment, the Phoenix Mecano Group increased its incoming orders by 28.2 % to EUR 522.5 million, compared with EUR 407.5 million the previous year.

522.5 MILLION EUR INCOMING ORDERS

At 61.9 %, the equity ratio remained at a high level, ensuring the stability and future of the company in spite of any market turbulence.

61.9 % EQUITY RATIO

The result of the period rose by 278.3 % in 2010, from EUR 11.6 million to an all-time high of EUR 43.9 million. The net margin rose to 8.7 %, topping even the boom year of 2008.

43.9 MILLION EUR RESULT OF THE PERIOD

## CONSOLIDATED BALANCE SHEET AS AT 31 DECEMBER 2010

## PHOENIX MECANO GROUP

Assets		2010	2009
1 000 EUR	Note		
<b>Non-current assets</b>			
Goodwill	3	18 647	1 012
Other intangible assets	4	22 136	8 632
Tangible assets	5	98 596	91 713
Investments in associated companies	6	502	541
Other financial assets	7	12	74
Derivative financial instruments	19	137	816
Deferred tax assets	22	2 832	2 215
<b>Total non-current assets</b>		<b>142 862</b>	<b>105 003</b>
<b>Current assets</b>			
Inventories	8	132 294	88 158
Trade receivables	9	52 266	47 194
Derivative financial instruments	19	1 589	955
Income tax receivables		4 762	3 113
Other receivables	10	8 536	7 487
Current securities	11	6 275	4 543
Cash and cash equivalents	12	31 800	42 593
Deferred charges and prepaid expenses		1 049	854
Assets held for sale	13	0	1 200
<b>Total current assets</b>		<b>238 571</b>	<b>196 097</b>
<b>Total assets</b>		<b>381 433</b>	<b>301 100</b>

Equity and liabilities		2010	2009
1 000 EUR	Note		
<b>Equity</b>			
Share capital	14	609	615
Treasury shares	15	-1 779	-5 290
Retained earnings		232 632	197 645
Profits/losses from IAS 39		938	721
Translation differences		2 360	-1 481
<b>Equity attributable to shareholders of the parent company</b>		<b>234 760</b>	<b>192 210</b>
Minority interest	16	1 466	1 155
<b>Total equity</b>		<b>236 226</b>	<b>193 365</b>
<b>Liabilities</b>			
Liabilities from financial leasing	17	38	110
Other long-term financial liabilities	18	33 650	19 439
Derivative financial instruments	19	24	0
Long-term provisions	20, 21	10 429	10 931
Deferred tax liabilities	22	5 654	4 905
<b>Long-term liabilities</b>		<b>49 795</b>	<b>35 385</b>
Trade payables	23	20 434	15 349
Short-term financial liabilities	24	29 249	23 813
Derivative financial instruments	19	138	57
Short-term provisions	20, 21	12 495	9 283
Income tax liabilities		14 236	10 456
Other liabilities	25	18 060	12 357
Deferred income		800	1 035
<b>Short-term liabilities</b>		<b>95 412</b>	<b>72 350</b>
<b>Total liabilities</b>		<b>145 207</b>	<b>107 735</b>
<b>Total equity and liabilities</b>		<b>381 433</b>	<b>301 100</b>

## CONSOLIDATED STATEMENT OF INCOME 2010

		2010	2009
1 000 EUR	Note		
Gross sales	33	501 558	396 913
Revenue reductions		-5 614	-4 810
<b>Net sales</b>		<b>495 944</b>	<b>392 103</b>
Changes in inventories		8 272	-26
Own work capitalised		748	776
Other operating income	34	4 608	4 799
<b>Total operating performance</b>		<b>509 572</b>	<b>397 652</b>
Cost of materials	35	-250 228	-194 978
Personnel expenses	36	-131 663	-115 601
Amortisation of intangible assets	37	-4 032	-3 457
Depreciation on tangible assets	38	-13 792	-14 416
Other operating expenses	39	-57 265	-55 657
<b>Operating expenses</b>		<b>-456 980</b>	<b>-384 109</b>
<b>Result before interest and tax (operating result)</b>		<b>52 592</b>	<b>13 543</b>
Result from associated companies		86	73
Financial income	40	4 227	4 202
Financial expenses	41	-6 058	-3 955
Financial result		-1 745	320
<b>Result before tax</b>		<b>50 847</b>	<b>13 863</b>
Income tax	42	-6 963	-2 263
<b>Result of the period</b>		<b>43 884</b>	<b>11 600</b>
of which			
Shareholders in the parent company		43 635	11 505
Minority shareholders		249	95
<b>Earnings per share</b>			
Earnings per share – undiluted (in EUR)	43	44.99	11.85
Earnings per share – diluted (in EUR)	43	44.99	11.85

## CONSOLIDATED STATEMENT OF COMPREHENSIVE INCOME 2010

1 000 EUR	Note	2010	2009
<b>Result of the period</b>		<b>43 884</b>	<b>11 600</b>
<b>Other result</b>			
Fluctuations in fair value of financial assets		86	52
Fluctuations in fair value of cash flow hedges		-261	986
Realised results of cash flow hedges		385	36
Translation differences attributable to the parent company		3 841	643
Translation differences attributable to minority interest		118	87
Deferred tax	22	7	-182
<b>Other result (after tax)</b>		<b>4 176</b>	<b>1 622</b>
<b>Comprehensive income</b>		<b>48 060</b>	<b>13 222</b>
of which			
Shareholders in the parent company		47 693	13 040
Minority shareholders		367	182

## CONSOLIDATED STATEMENT OF CASH FLOW 2010

		2010	2009
1 000 EUR	Note		
Result of the period		43 884	11 600
Income tax		6 963	2 263
<b>Result before tax</b>		<b>50 847</b>	<b>13 863</b>
Amortisation of intangible assets	4	4 032	3 457
Depreciation on tangible assets	5	13 792	14 416
Losses/(gains) from the disposal of intangible and tangible assets	34, 39	68	-92
Impairment losses/(reversal of impairment losses) on intangible and tangible assets	4, 5	744	2 487
Losses and value adjustments on inventories	8	-118	3 617
Result from associated companies	6	-86	-73
Other non-cash expenses/(income)		1 287	-1 715
Increase/(decrease) in long-term provisions		-585	1 589
Net interest expenses/(income)	40, 41	513	859
Interest paid		-1 152	-1 414
Income tax paid		-8 636	-3 915
<b>Operating cash flow before changes in working capital</b>		<b>60 706</b>	<b>33 079</b>
(Increase)/decrease in inventories		-37 633	13 638
(Increase)/decrease in trade receivables		-2 467	685
(Increase)/decrease in other receivables, deferred charges and prepaid expenses		-1 005	-1 247
(Decrease)/increase in trade payables		3 479	570
(Decrease)/increase in short-term provisions		2 863	-63
(Decrease)/increase in other liabilities and deferred income		3 418	56
<b>Cash flow from operating activities</b>		<b>29 361</b>	<b>46 718</b>



1 000 EUR	Note	2010	2009
<b>Capital expenditure</b>			
Intangible assets	4	-1 347	-1 152
Tangible assets	5	-18 296	-10 943
Financial assets		0	-183
Current securities		-2 225	-4 094
Purchase of minority shareholder shares		-96	0
Acquisition of Group companies	46	-18 914	-19 824
<b>Disinvestments</b>			
Intangible assets		40	2
Tangible assets		1 915	448
Financial assets		528	258
Current securities		930	953
Disposal of Group companies	47	625	0
Interest received		634	465
Dividends received		125	200
<b>Cash flow used in investing activities</b>		<b>-36 081</b>	<b>-33 870</b>
Dividends paid (including minority interest)		-6 859	-6 464
Capital increase from minority shareholders		0	50
Purchase of treasury shares		-644	-4 771
Sale of treasury shares		2 400	283
Issue of financial liabilities		11 682	16 503
Repayment of financial liabilities		-11 672	-15 233
<b>Cash flow from financing activities</b>		<b>-5 093</b>	<b>-9 632</b>
Translation differences in cash and cash equivalents		1 020	222
<b>Change in cash and cash equivalents</b>		<b>-10 793</b>	<b>3 438</b>
Cash and cash equivalents as at 1 January	12	42 593	39 155
Cash and cash equivalents as at 31 December	12	31 800	42 593
<b>Change in cash and cash equivalents</b>		<b>-10 793</b>	<b>3 438</b>

# CONSOLIDATED STATEMENT OF CHANGES IN EQUITY 2010

		Share capital	Treasury shares	Retained earnings
1 000 EUR	Note			
<b>Equity as at 31 December 2008</b>		<b>665</b>	<b>-24 529</b>	<b>216 281</b>
Fluctuations in fair value of financial assets				
Realised results of financial assets				
Realised results of cash flow hedges				
Translation differences				
Deferred taxes not affecting income				
<b>Total other result (after tax)</b>		<b>0</b>	<b>0</b>	<b>0</b>
<b>Result of the period</b>				<b>11 505</b>
<b>Total comprehensive income</b>		<b>0</b>	<b>0</b>	<b>11 505</b>
Change in scope of consolidation				
Capital increase	15	-50	23 507	-23 457
Change in treasury shares	15		-4 268	-220
Dividends paid				-6 464
<b>Total equity transactions with owners</b>		<b>-50</b>	<b>19 239</b>	<b>-30 141</b>
<b>Equity as at 31 December 2009</b>		<b>615</b>	<b>-5 290</b>	<b>197 645</b>
Fluctuations in fair value of financial assets				
Fluctuations in fair value of cash flow hedges				
Realised results of cash flow hedges				
Translation differences				
Deferred taxes not affecting income				
<b>Total other result (after tax)</b>		<b>0</b>	<b>0</b>	<b>0</b>
<b>Result of the period</b>				<b>43 635</b>
<b>Total comprehensive income</b>		<b>0</b>	<b>0</b>	<b>43 635</b>
Change in scope of consolidation				-50
Capital decrease	15	-6	2 399	-2 393
Change in treasury shares	15		1 112	644
Dividends paid				-6 849
<b>Total equity transactions with owners</b>		<b>-6</b>	<b>3 511</b>	<b>-8 648</b>
<b>Equity as at 31 December 2010</b>		<b>609</b>	<b>-1 779</b>	<b>232 632</b>

	Profits/(losses) Cash flow hedge from IAS 39	Profits/(losses) financial assets IAS 39	Translation differences	Equity attribut- able to share- holders of the parent company	Minority interest	Total equity
	12	-183	-2 124	190 122	923	191 045
		52		52		52
	986			986		986
	36			36		36
			643	643	87	730
	-182			-182		-182
	840	52	643	1 535	87	1 622
				11 505	95	11 600
	840	52	643	13 040	182	13 222
					50	50
				0		0
				-4 488		-4 488
				-6 464		-6 464
	0	0	0	-10 952	50	-10 902
	852	-131	-1 481	192 210	1 155	193 365
		86		86		86
	-261			-261		-261
	385			385		385
			3 841	3 841	118	3 959
	7			7		7
	131	86	3 841	4 058	118	4 176
				43 635	249	43 884
	131	86	3 841	47 693	367	48 060
				-50	-46	-96
				0		0
				1 756		1 756
				-6 849	-10	-6 859
	0	0	0	-5 143	-56	-5 199
	983	-45	2 360	234 760	1 466	236 226

# CONSOLIDATED SEGMENT INFORMATION 2010

By division	Enclosures		ELCOM/EMS	
	2010	2009	2010	2009
1 000 EUR				
<b>Gross sales to third parties</b>	<b>146 460</b>	<b>120 376</b>	<b>156 091</b>	<b>94 822</b>
Gross sales between divisions	414	394	4 045	3 962
Impairment losses on intangible and tangible assets	-74	-102	-36	-700
Amortisation of intangible assets and depreciation on tangible assets	-5 867	-6 019	-5 578	-4 922
<b>Result before interest and tax (operating result)</b>	<b>26 940</b>	<b>17 428</b>	<b>18 148</b>	<b>3 626</b>
Financial result				
<b>Result before tax</b>				
Income tax				
<b>Result of the period</b>				
<b>Investments in intangible and tangible assets</b>	<b>4 041</b>	<b>3 221</b>	<b>10 345</b>	<b>2 044</b>
Segment assets	77 997	71 238	102 075	59 975
Assets held for sale				
Cash and cash equivalents				
Other assets				
<b>Total assets</b>	<b>77 997</b>	<b>71 238</b>	<b>102 075</b>	<b>59 975</b>
Segment liabilities	17 687	13 890	12 486	10 728
Financial and other liabilities				
<b>Total liabilities</b>	<b>17 687</b>	<b>13 890</b>	<b>12 486</b>	<b>10 728</b>
<b>Net operating assets</b>	<b>60 310</b>	<b>57 348</b>	<b>89 589</b>	<b>49 247</b>

\* Included under Reconciliation are individual business areas and central management and financial functions that cannot be allocated to the divisions.

By region	Gross sales in third parties		Long-term assets (tangible and intangible assets)	
	2010	2009	2010	2009
1 000 EUR				
Switzerland	22 660	16 511	7 077	6 443
Germany	246 708	188 507	63 295	54 273
UK	15 449	15 061	101	145
France	22 443	22 786	469	635
Italy	14 842	11 676	1 659	1 762
Benelux	23 076	21 790	1 224	1 167
Rest of Europe	55 152	44 636	27 358	21 372
North and South America	54 424	41 121	5 585	5 410
Middle and Far East	46 804	34 825	32 611	10 150
<b>Total</b>	<b>501 558</b>	<b>396 913</b>	<b>139 379</b>	<b>101 357</b>

## Significant clients

The Phoenix Mecano Group has one individual customer generating revenue that accounted for over 10 % of the Group's sales in 2010. There were no such customers in 2009.

	Mechanical Components		Total segments		Reconciliation*		Total Group	
	2010	2009	2010	2009	2010	2009	2010	2009
	<b>197 419</b>	<b>180 352</b>	<b>499 970</b>	<b>395 550</b>	<b>1 588</b>	<b>1 363</b>	<b>501 558</b>	<b>396 913</b>
	48	16	4 507	4 372	-4 507	-4 372	0	0
	-634	-1 625	-744	-2 427	0	-60	-744	-2 487
	-6 142	-6 466	-17 587	-17 407	-237	-466	-17 824	-17 873
	<b>10 929</b>	<b>-4 871</b>	<b>56 017</b>	<b>16 183</b>	<b>-3 425</b>	<b>-2 640</b>	<b>52 592</b>	<b>13 543</b>
							-1 745	320
							<b>50 847</b>	<b>13 863</b>
							-6 963	-2 263
							<b>43 884</b>	<b>11 600</b>
	<b>5 082</b>	<b>6 654</b>	<b>19 468</b>	<b>11 919</b>	<b>175</b>	<b>176</b>	<b>19 643</b>	<b>12 095</b>
	148 655	109 018	328 727	240 231	2 525	2 700	331 252	242 931
					0	1 200	0	1 200
					31 800	42 593	31 800	42 593
					18 381	14 376	18 381	14 376
	<b>148 655</b>	<b>109 018</b>	<b>328 727</b>	<b>240 231</b>	<b>52 706</b>	<b>60 869</b>	<b>381 433</b>	<b>301 100</b>
	26 937	19 776	57 110	44 394	5 054	4 450	62 164	48 844
					83 043	58 891	83 043	58 891
	<b>26 937</b>	<b>19 776</b>	<b>57 110</b>	<b>44 394</b>	<b>88 097</b>	<b>63 341</b>	<b>145 207</b>	<b>107 735</b>
	<b>121 718</b>	<b>89 242</b>	<b>271 617</b>	<b>195 837</b>	<b>-35 391</b>	<b>-2 472</b>	<b>236 226</b>	<b>193 365</b>

## By product group

	Gross sales to third parties	
	2010	2009
1 000 EUR		
Industrial enclosures	130 686	109 470
Membrane keyboards	15 774	10 906
<b>Enclosures</b>	<b>146 460</b>	<b>120 376</b>
Electro-mechanical components	52 545	36 960
Power quality	78 871	38 103
Electronic packaging	24 675	19 759
<b>ELCOM/EMS</b>	<b>156 091</b>	<b>94 822</b>
Industrial assembly systems	28 829	23 567
Linear adjustment and positioning systems	168 590	156 785
<b>Mechanical Components</b>	<b>197 419</b>	<b>180 352</b>
<b>Reconciliation</b>	<b>1 588</b>	<b>1 363</b>
<b>Total</b>	<b>501 558</b>	<b>396 913</b>

# PRINCIPLES OF CONSOLIDATION AND VALUATION

## ACCOUNTING PRINCIPLES

Phoenix Mecano AG with its subsidiaries (the Phoenix Mecano Group) operates worldwide as a manufacturer and seller of components for industrial customers in the electronics, electrical and mechanical engineering segments as well as of electric drives and control systems for adjustable ergonomic and healthcare furniture and hospital and healthcare beds. It is the leader in many of its markets. The Group's main activities are presented under Segment Information. Phoenix Mecano AG has its head office in Stein am Rhein, Switzerland, and has been listed on the Swiss exchange (SIX) since 1988. Its address is Hofwisenstrasse 6, CH-8260 Stein am Rhein.

The consolidated financial statements of Phoenix Mecano AG were drawn up in accordance with International Financial Reporting Standards (IFRS) and comply with Swiss law.

Where subsidiaries have a financial year that differs from the period under consideration, interim statements are drawn up and audited. Thus the consolidated financial statements are based upon audited annual or interim financial statements as at 31 December 2010, which in turn are based on the standard accounting, valuation and organisation criteria that are applied uniformly throughout the Group.

The consolidated financial statements were drawn up in accordance with the principle of historical acquisition and manufacturing cost. As an exception to this, financial assets held for sale, receivables and liabilities from derivative financial instruments and liabilities hedged by fair value hedges are valued at fair value. In addition, assets held for sale (intangible assets, tangible assets) are valued at fair value, provided that this value is lower than the book value. The consolidated statement of income was drawn up using the total cost method.

### Application of new accounting standards

The following new IFRS/IAS standards and IFRIC interpretations were applied for the first time from 1 January 2010:

- › IFRS 3 rev. – Business Combinations
- › IAS 27 rev. – Consolidated and Separate Financial Statements according to IFRS
- › Amendments to IAS 39 – Financial Instruments: Recognition and Measurement – Exposures Qualifying for Hedge Accounting
- › IFRIC 17 – Distributions of Non-cash Assets to Owners
- › Amendments to IFRSs 2008 – Amendments to IFRS 5 – Non-current Assets Held for Disposal and Discontinued Operations
- › General amendments to IFRS Standards (April 2009)
- › Amendments to IFRS 2 – Group Cash-settled Share-based Payment Transactions

With the exception of IFRS 3 rev., the application of the new or revised IFRS/IAS standards and IFRIC interpretations had no impact on accounting, measurement and presentation or on the scope of the notes to the financial statements. The amendments to IFRS 3 require that contingent purchase price payments be recognised at fair value at the acquisition date. The liability is then adjusted to the current market value in income/expense. For the measurement of minority interests (or non-controlling interests, NCIs), there is a choice available on a transaction-by-transaction basis: they can be measured either at fair value or at the NCI's proportionate share of net assets of the acquiree. Directly attributable transaction costs must be recognised in the current statement of income.

The following new and revised standards and interpretations have been approved but will only enter into force at a later date and as such have not been applied in these consolidated financial statements. Their impact on the Phoenix Mecano consolidated financial statements has not yet been systematically analysed; consequently, the expected effects listed at the base of the table are an initial estimate only.

			Entry into force	Planned implementation by Phoenix Mecano
<b>New standards or interpretations</b>				
IFRIC 19	Extinguishing Financial Liabilities with Equity Instruments	<sup>1</sup>	1 July 2010	Financial year 2011
IFRS 9	Financial Instruments: Classification and Measurement	<sup>2</sup>	1 January 2013	Financial year 2013
<b>Revisions and amendments of standards and interpretations</b>				
Amendment to IAS 32	Financial Instruments: Presentation – Classification of Rights Issues	<sup>1</sup>	1 February 2010	Financial year 2011
IAS 24 (rev. 2009)	Related Party Disclosures	<sup>1</sup>	1 January 2011	Financial year 2011
Amendments to IFRIC 14	IAS 19 – The Limit on a Defined Benefit Asset, Minimum Funding Requirements and their Interaction – Prepayments of a Minimum Funding Requirement	<sup>1</sup>	1 January 2011	Financial year 2011
Amendments to IFRSs (May 2010)		<sup>1</sup>	1 July 2010 1 January 2011	Financial year 2011
Amendments to IFRS 7	Disclosures – Derecognition of Financial Assets	<sup>1</sup>	1 July 2011	Financial year 2012
Amendment to IAS 12	Deferred Tax: Recovery of Underlying Assets	<sup>1</sup>	1 January 2012	Financial year 2012

<sup>1</sup> No or negligible impact expected on Phoenix Mecano's consolidated financial statements.

<sup>2</sup> Impact on Phoenix Mecano's consolidated financial statements cannot yet be determined with sufficient certainty.

### Scope of consolidation

The consolidated financial statements cover all companies over which Phoenix Mecano AG exercises direct or indirect control. Control means exercising a decisive influence on financial and operational activity with a view to deriving corresponding benefit. This is the case where Phoenix Mecano AG directly or indirectly holds over 50 % of the voting rights in a company or where its management of the company is contractually guaranteed or exercised in practice.

The integrated Group companies are combined using the full consolidation method. 100 % of all assets and liabilities, as well as income and expenditure, are included in the consolidated financial statements, with the exception of items that are eliminated during consolidation. Minority interests in equity are posted separately as a sub-item under equity. The minority share in the income is shown separately in the consolidated statement of income as a part of the result of the period. Newly acquired participating interests are included in the consolidated financial statements from the date on which control was acquired, while companies disposed of during the reporting year are excluded from the date on which control was relinquished.

### Associated companies

Investments in associated companies, in which Phoenix Mecano has a voting share of between 20 and 50 % or exerts a significant influence in some other way, as with joint ventures (50 % interests, which Phoenix Mecano controls jointly with partners), are included in the consolidated financial statements in accordance with the equity method. Under the equity method, the fair value of the proportionate net assets at the acquisition date is calculated and recognised together with any goodwill under Investments in associated companies. In the subsequent reporting periods, this value is adjusted by the share of the Phoenix Mecano Group in the additional capital and result generated as well as by any dividends.

### Capital consolidation

Capital consolidation at the acquisition is based on the acquisition method. The purchase price for a company acquisition is determined based on the total of the fair value of the assets given, the liabilities incurred or assumed and the equity instruments issued by the Phoenix Mecano Group. Transaction costs associated with a company acquisition are recognised as income/expense. The goodwill arising from a company acquisition is recognised as an asset. It corresponds to the surplus of the total of the purchase price, contribution of minority interests in the company being taken over and the balance of assets, liabilities and contingent liabilities at fair value. Minority interests are measured based on the minority share in the fair value of the net assets taken over. In the event of a negative difference, the remaining surplus is reported directly as income/expense following a further measurement of the fair value of the net assets taken over.

A contingent purchase price payment is measured at fair value at the acquisition date. Subsequent adjustments are reported as an adjustment to goodwill if they are based on more accurate information about the fair value at the acquisition date and provided they occur within the measurement period, i.e. a period of 12 months. All other subsequent adjustments are recognised as income/expense.

If the Phoenix Mecano Group offers a seller a put option on the remaining minority interest at the time of acquisition, resulting in a de facto obligation to buy, this option is recognised as a liability and measured at fair value. Subsequent adjustments to the liability are also recognised as income/expense. Accordingly, no minority interest is reported in the consolidated financial statements.

### Currency conversion

Owing to the great importance of the Euro to the Group – most of Phoenix Mecano's sales are made in Euro and most of its major subsidiaries are located in the Euro area – the consolidated financial statements are presented in Euro.

The items contained in a Group company's annual accounts are valued on the basis of the currency of the primary economic environment in which the company operates (functional currency). Foreign currency transactions are converted into the functional currency at the exchange rates prevailing at the time of the transaction. Gains and losses resulting from the transactions themselves and from the conversion of monetary assets and liabilities in foreign currencies at the relevant closing rate are reported in the statement of income.



The results and balance sheet items of all Group companies with a functional currency other than the reporting currency, Euro, are converted to Euro. The assets and liabilities are converted at the closing rate for each balance sheet date, income and expenses at the average exchange rate for each statement of income. Any resulting translation differences and any translation differences on long-term loans which are considered to be similar in nature to equity are posted in equity as a separate item. The statement of cash flow is converted at the average exchange rate.

### Intercompany profits

Intercompany profits on inventories and non-current assets arising from trading between companies within the Group are eliminated so as not to affect income. Unrealised losses on transactions within the Group are also eliminated, unless the transaction indicates an impairment of the transferred asset.

### Segment information

The segment information is presented in accordance with internal reporting and follows the management approach.

The Phoenix Mecano Group is divided into three divisions (operating segments). An operating segment is a component of a company which engages in business activities from which it may earn revenues and incur expenses. Its operating results are reviewed regularly by the chief operating decision maker (CODM) in order to make decisions about resources to be allocated to the segment and assess its performance. Discrete financial information is available for the segment. The Group's divisions are as follows:

- › **Enclosures** (enclosures made of aluminium, plastic and glass-fibre reinforced polyester, machine control boards and suspension systems for protecting electronics in an array of industrial applications, membrane keyboards)
- › **ELCOM/EMS** (coding switches, inductive components, transformers, plug connectors, back-planes, power supply systems, circuit board equipment, the development of customised electronic applications right down to complete subsystems)
- › **Mechanical Components** (aluminium profile assembly systems, linear positioning systems, industrial terminals and linear drives for mechanical engineering and electrically adjustable furniture for the home and hospital care sector).

These form the basis for the segment reporting. In addition, individual business areas that are not allocated directly to the above three divisions are included under "Reconciliation", as are central management and financial functions. Also recorded under Reconciliation are asset and liability items that are not allocated to the divisions (cash and cash equivalents, other assets and financial and other liabilities).

Sales between individual divisions are invoiced on arms-length terms.

The result is allocated to the individual divisions to the level of the result before interest and tax.

Segment assets include intangible assets, tangible assets, inventories, trade receivables, other receivables (minus financial and interest receivables) and deferred charges and prepaid expenses of the respective business division. Operating liabilities include provisions, trade payables, other liabilities (minus interest liabilities) and deferred income per business division. The remaining asset and liability items are recorded under Reconciliation. Measurement in the segment information is based on the same accounting principles as used in the IFRS consolidated financial statements.

### Goodwill

Goodwill (see above under Capital consolidation) is tested for impairment annually and, if there are any indications of a reduction in value, it is also tested during the period. Any resulting impairment losses are reported in income. No reversal of impairment losses is performed.

### Other intangible assets

**Capitalised development costs** Development costs for new products, which satisfy the criteria for capitalisation specified by IAS 38 (in particular there must be the prospect of a net income), are capitalised at acquisition or manufacturing cost and written off over the respective useful life, which must not exceed five years. Otherwise, research and development costs are debited directly to the statement of income.

**Concessions, licences, similar rights and assets** These other intangible assets are valued at acquisition cost less accumulated depreciation and, where appropriate, additional impairment losses. The depreciation rates are determined on a straight-line basis over the estimated useful life of the asset, which must not exceed ten years, in accordance with standard Group practice. Financing costs are capitalised in accordance with IAS 23.

Phoenix Mecano possesses no other intangible assets with an indeterminate useful life.

### Tangible assets

Tangible assets are stated in the balance sheet at no more than the acquisition or manufacturing cost, less accumulated depreciation and where appropriate less additional impairment losses. The straight-line method of depreciation is applied over the depreciation periods specified in the useful life categories used by the whole Group. Where components of larger assets have different useful lives, these are depreciated as separate items. Financing costs are capitalised in accordance with IAS 23.

Follow-on investments are only capitalised if the Group is likely to derive future economic benefit as a result and if the costs can be reliably determined.

The useful lives of assets are estimated as follows:

Land	unlimited useful life
Buildings	35 years
Outside facilities and building installations	10–15 years
Machinery and equipment	4–10 years

**Leased assets**

As a rule, lease contracts are only included in the balance sheet as financial lease contracts if the risks and rewards associated with ownership belong largely to the Group company when the contract is concluded. They are valued at the present value of the minimum lease rates or at the lower market value. The corresponding financial leasing commitments are posted as liabilities. The leasing rates are divided up into interest and repayment sums in accordance with the annuity method. The leased assets are depreciated over the estimated useful life or shorter lease term.

Operating lease payments are expensed directly to the statement of income on a straight-line basis over the lease term.

**Devaluation losses (impairment)**

Goodwill is checked annually for impairment. Other intangible and tangible assets are consistently checked for impairment if there are indications to suggest that this has taken place. The realisable value (the higher of the fair value less costs to sell and the value in use) of the asset or the cash generating unit is estimated and a revenue adjustment to the previous book value is made, provided the latter exceeds the realisable value. The value in use corresponds to the present value of the expected future cash flows of the respective asset.

Previously recognised impairment losses are reversed (except on goodwill) if the estimates used to calculate the recoverable amount have altered and the impairment has reduced or disappeared as a result. The increase in book value may not exceed the amount that would have resulted if no impairment loss had been reported for the asset in the preceding years.

The discount rate is determined based on the pre-tax weighted average cost of capital (WACC) of Phoenix Mecano. Because of their differing risk profiles, there is a differentiation between the Phoenix Mecano Group's individual cash generating units.

**Investments in associated companies**

Investments shown under this item are valued in accordance with the criteria set out above under Associated companies.

**Other financial assets**

Long-term loans to associated companies and third parties contained in Other financial assets are posted at their fair value upon initial recognition and at amortised cost in subsequent periods, taking account of any reductions in value (impairment) through corresponding devaluations which affect net income.

The other investments under 20 % shown under Other financial assets are posted at fair value. Resulting changes in value are posted under Equity or under Other result in the statement of comprehensive income without affecting operating income and only transferred to the statement of income in the event of sale or an impairment (treated as available-for-sale financial assets in accordance with IAS 39). If the fair value cannot be reliably determined, the valuation is made at acquisition costs. Any reductions in value (impairment) are taken into account through corresponding devaluations (affecting net income) of the amount still likely to be recovered. Such impairment is not reversed.

A key factor in deciding whether to derecognise a financial asset is the transfer of the associated risks and rewards (known as the 'risks and rewards' approach).

**Inventories**

Inventories are reported at acquisition or production cost, which must not exceed the realisable net value (lowest value principle). The value of the costs is determined in the same way throughout the Group by means of the weighted average method. The production costs include all material costs, production wages and pro rata manufacturing overheads. Appropriate value adjustments are made for inventory-related risks wherever necessary, based on corresponding analyses of scope or coverage.

**Receivables**

Receivables are reported at amortised cost (usually equivalent to their nominal value) less value adjustments for bad debts. The value adjustment consists of individual value adjustments for specifically identified items, for which there is objective evidence to suggest that the outstanding amount will not be received in full, as well as flat-rate value adjustments for groups of receivables with a similar risk profile. The flat-rate value adjustments cover losses that are expected but not yet known and are based on age structure and historical receivables payment statistics. Where there is sufficient evidence to suggest that a receivable is definitely uncollectable, the receivable is derecognised directly. Subsequent incoming payments on amounts that have been derecognised are reported in income. Accounts payable and receivable between Group companies are offset against one another, provided that the companies are consolidated.

**Current securities**

Securities are measured at fair value, both on initial recognition and subsequently. This corresponds to the market price in effect on the balance sheet date. Fluctuations in the market value of securities are recorded under Other result and only included in the statement of income in the event of sale or an impairment (treated as available-for-sale financial assets in accordance with IAS 39). Any reductions in value (impairment) are taken into account through corresponding devaluations which affect net income. Impairment on equity instruments is not reversed in a way that affects net income. Accumulated interest on bonds is deferred.

**Cash and cash equivalents**

Cash and cash equivalents comprises cash on hand, in bank and in postal accounts, together with cheques. It also includes fixed deposits with a term not exceeding three months from the date of acquisition.

**Assets held for sale**

Long-term assets are classified as held for sale and shown on the balance sheet in a separate item under assets or liabilities if the book value is to be realised by selling, rather than using, the assets. This is conditional upon the sale being very likely to take place and the assets being ready for immediate sale. For a sale to be classified as very likely, it must meet a number of criteria, including being expected to take place within one year.

Assets held for sale are valued at the lower of the book value or the fair value less costs to sell. From the time they are classified as 'for sale', depreciable assets are no longer depreciated.

### Financial liabilities

Upon initial recognition, financial liabilities are recorded at fair value less transaction costs. In subsequent periods they are valued at amortised costs. Any discrepancy between the disbursement amount (less transaction costs) and the repayable amount is amortised throughout the term using the effective interest method and reported in income. Residual purchase price obligations from acquisitions are revalued at the balance sheet date and measured at fair value.

Short-term liabilities are those with a remaining term of less than one year.

A financial liability is derecognised when it is cancelled or when it is discharged either judicially or by the creditor.

### Provisions

Provisions are formed if a past event has resulted in a present legal or actual obligation and there is likely to be an outflow of funds which can be reliably determined.

Restructuring provisions are recognised if, on the balance sheet date, there exists a corresponding liability with respect to a restructuring measure.

### Employee benefits

**Pension obligations** The Group does not operate its own pension schemes. Pensions are essentially secured by external, independent pension providers in accordance with the defined contribution principle. The pension solution adopted for the Group's Swiss companies is affiliation to a collective foundation (Sammelstiftung) with its own legal personality, financed through employer and employee contributions. This pension plan is assessed under IAS 19 as defined benefit and is included in the balance sheet accordingly. In several Group companies in Germany, existing pension plans are also treated as defined benefit pension plans. Corresponding pension provisions are posted on the balance sheet for these plans.

The obligations associated with defined benefit pension plans are assessed annually for each plan by calculating the present value of the expected claims using the projected unit credit method and then subtracting or adding the market value of the plan assets, unrecognised actuarial gains and losses and unrecognised past service cost. The discount rate is based on the interest rate for top-quality corporate bonds with similar durations to the obligations. The obligation is calculated annually by independent insurance experts.

Pension costs linked to service during the reporting period are recognised as income/expense. The increase in pension costs for past service resulting from new or improved pension benefits is recorded on a straight-line basis under staff pension expenses until entitlement can be claimed. If there is immediate entitlement, these costs are recognised as income/expense immediately.

Actuarial gains and losses resulting from periodic recalculations are recognised as income/expense on a straight-line basis over the average remaining working life, provided they exceed 10 % of the greater of the plan assets and pension obligation.

Surplus cover is only capitalised up to an amount that does not exceed the total of the unrecognised past service cost, unrecognised actuarial gains and losses and the benefits from future contribution repayments or reductions. With defined contribution pension plans, the expenses posted in the statement of income correspond to the payments made by the employer.

**Other long-term employee benefits** Corresponding provisions are made for existing obligations based on statutory retirement pay in Italy ("Trattamento Fine Rapporto"), agreements providing for part-time work for older employees in Germany and service anniversaries. The amount is determined in conformity with IAS 19 using the projected unit credit method. Actuarial gains and losses are recognised as income/expense in the period in which they occur.

**Employee participation plans** There are no employee participation plans.

#### **Trade payables and other liabilities**

Trade payables and other liabilities are entered at amortised cost, which generally corresponds to their nominal value.

#### **Equity**

Treasury shares are deducted from equity and posted as a separate item within equity. Gains and losses on Treasury shares are posted without affecting operating income.

Dividends are posted in the consolidated financial statements in the period in which they were agreed upon by the Shareholders' General Meeting of Phoenix Mecano AG.

#### **Derivative financial instruments**

All derivative financial instruments are measured at fair value in accordance with IAS 39 and are recognised separately in the Group balance sheet. For instruments traded in an active market, the fair value corresponds to the market value on the balance sheet date; for other instruments, it corresponds to the value determined on the basis of mathematical models. Book gains and losses from derivative financial instruments are dealt with as described below.

Hedging transactions which meet the requirements of IAS 39 regarding hedge accounting are governed by the relevant provisions set out in that standard. In the case of a fair value hedge, i.e. the hedging of an existing underlying transaction (assets or liabilities reported in the balance sheet), the changes in market value from both the underlying transaction and the hedging transaction are recognised in the financial result as income/expense and the underlying hedged transaction is valued at fair value. In the case of a cash flow hedge, i.e. the hedging of future cash flows, the change in market value from the hedging transaction is shown in equity without affecting net income. As soon as the hedged transaction has taken place, the accumulated gains and losses are carried over into the statement of income. As part of its risk policy, the Group also hedges interest and currency risks that are not treated as hedge accounting as defined by IAS 39. Changes in the market value of derivative financial instruments used in this way are recognised directly in the financial result as income/expense.

**Realisation of income**

Sales are realised upon service delivery and transfer of ownership or risk to the customer. Interest income is recognised on an accrual basis. Dividend income from securities is recorded at the time of payment.

There are no long-term manufacturing orders which are recorded in accordance with the progress of performance.

**Government subsidies**

Investment incentives are deferred and systematically reported in income in accordance with the straight-line method over the useful life of the supported asset. Allowances for research and development accordingly reduce the costs incurred in this area.

**Income tax**

Income tax covers both current and deferred income taxes. They are reflected in the statement of income, with the exception of income taxes on transactions reported directly in equity or under Other result. In such cases, the corresponding income taxes are also recognised directly in equity or under Other result in the statement of comprehensive income.

Current income taxes include expected tax owed on the taxable result, calculated according to the tax rates prevailing on the balance sheet date and adjustments to tax liabilities or credits from previous years.

Deferred taxes are calculated on temporary differences between the values in the tax accounts and the consolidated financial statements in accordance with the balance sheet liability method. No deferred taxes on the valuation differences upon initial recognition of goodwill or on investments in subsidiary companies and residual purchase price liabilities on acquisitions are taken into consideration, if these differences are unlikely to cancel each other out in the foreseeable future. Calculation of the deferred taxes takes into account when and how the realisation or repayment of the relevant assets and liabilities is likely to take place. This calculation uses the tax rates prevailing or announced on the balance sheet date.

Future tax savings on the basis of tax losses carried forward and temporary differences are only capitalised if their realisation seems certain. For this to be the case, consistently positive results must have been achieved and be expected to continue in the foreseeable future. If there are taxable temporary differences and offsettable tax losses carried forward at the same company, the two amounts are offset against one another.

Non-reclaimable withholding taxes on distributions on the profits of foreign subsidiaries are only recorded as a liability if such distributions are planned.

**Statement of cash flow**

Cash flow from operating activities is calculated using the indirect method. The funds consist of cash and cash equivalents.

**Assumptions and estimations**

Accounting requires assumptions and estimations to be made which influence the amount of the accounted assets and liabilities, the amount of contingent liabilities and contingent claims as at the balance sheet date and also expenses and income from the reporting periods. The assumptions and estimations are based on historical knowledge and experience and on the information available when the balance sheet is being drawn up. They are considered accurate under the circumstances. If estimations and assumptions made by the management based on the best knowledge available at the time of balance sheet preparation differ from the actual circumstances subsequently observed, the original estimations and assumptions are adapted accordingly in the reporting year in which the circumstances altered.

The most important assumptions and estimations are set out below:

**Intangible and tangible assets** These are tested for impairment annually. The anticipated cash flow generated by the use or disposal of the assets in question is estimated in order to ascertain whether impairment applies. Especially where company property is concerned, impairment is linked to unfavourable locations, product-specific manufacturing plants and tools and capitalised development services associated with a wide range of uncertainties. For the book values of intangible and tangible assets, see notes 4 and 5.

**Inventories** A complex supply chain within the Group (including as a result of production in cost-efficient locations and processing service in the sales companies) and the high priority accorded to short delivery times for customers require an adequate supply inventory and result in comparatively low stock turnaround figures. Some electrotechnical components can only be stored for a limited amount of time, since otherwise they are no longer suitable for soldering. As a result, there are increased stock risks. On the basis of corresponding stock turnaround and storage period analyses, estimations and assessments on recoverability and devaluation requirements are carried out. For the book values of inventories, see note 8.

**Provisions** Guarantee provisions are calculated based on estimates of potential future guarantees and on past experience. There is a higher guarantee risk for products of Dewert Antriebs- und Systemtechnik GmbH (D) which are used in the hospital and care sector. Individual Group companies are exposed to litigation. On the basis of currently available knowledge, an assessment of the potential consequences of these court cases was conducted and provisions were constituted where necessary. For the book values of provisions, see note 20.



**Financial liabilities** To determine the residual purchase price liabilities from acquisitions, estimates of the medium-term business development of the company concerned must be performed, with all the uncertainties that these entail.

**Pension obligations** Pension obligations from defined benefit plans are determined based on statistical and actuarial calculations made by external assessors, which in turn are based on a wide range of assumptions (about salary trend, pension trend, life expectancy and so on). For the book values of the pension obligations posted on the balance sheet, see note 21.

**Gross sales** The deferral of sales revenue requires an assessment regarding the time when the main risks and benefits were transferred to the customer.

**Income tax** Extensive estimations based on existing tax legislation and regulations are required to determine receivables and liabilities from current and deferred income taxes.

## NOTES TO THE CONSOLIDATED FINANCIAL STATEMENTS 2010

**1 Currency exchange rates**

Euro for	Balance sheet		Statements of income and cash flow	
	2010	2009	2010	2009
1 CHF	0.801	0.674	0.725	0.662
1 GBP	1.166	1.126	1.166	1.123
1 USD	0.750	0.698	0.755	0.720
100 HUF	0.360	0.371	0.363	0.357
1 RON	0.234	0.236	0.239	0.237
1 SEK	0.111	0.098	0.105	0.094
1 TND	0.528	0.534	0.533	0.542
1 SGD	0.583	0.496	0.554	0.495
1 CNY	0.114	0.102	0.111	0.105
1 BRL	0.450	0.400	0.431	0.363
1 INR	0.017	0.015	0.017	0.015
1 AUD	0.765	0.627	0.693	0.566

**2 Scope of consolidation**

In 2010 and 2009 the scope of consolidation changed as follows:

**Change**

Date	Company	Change	Division
<b>2010</b>			
01.01.2010	AKOM Agentur für Marketing GmbH	Merger with Rose Systemtechnik GmbH	Reconciliation
01.05.2010	Lohse GmbH	Acquisition	ELCOM/EMS
26.08.2010	IPES Industria de Produtos e Equipamentos de Solda Ltda.	Sale	Reconciliation
22.11.2010	Phoenix Mecano Hong Kong Ltd.	Foundation	Mechanical Components
22.11.2010	Okin Refined Electric Technology Co. Ltd.	Foundation of joint venture	Mechanical Components
<b>2009</b>			
01.01.2009	MCT Moderne Contact Technologie GmbH	Merger with IFINA Beteiligungsgesellschaft mbH	Reconciliation
01.01.2009	RK Schmidt Systemtechnik GmbH	Acquisition of business operations of Eiden & Schmidt GmbH Messtechnik	Mechanical Components
05.02.2009	Okin Motion Technologies GmbH	Acquisition	Mechanical Components
05.02.2009	Okin Hungary Gépgyártó Kft.	Acquisition	Mechanical Components
05.02.2009	Okin Scandinavia AB	Acquisition	Mechanical Components
05.02.2009	Okin America Inc.	Acquisition	Mechanical Components
27.10.2009	Phoenix Mecano ApS	Foundation	Mechanical Components

The following companies were fully consolidated as at 31 December 2010:

#### Scope of consolidation

Company	Head office	Activity	Currency	Registered capital in 1 000	Stake in %
Phoenix Mecano AG	Stein am Rhein, Switzerland	Finance	CHF	978	n/a
Phoenix Mecano Management AG	Kloten, Switzerland	Finance	CHF	50	100
Phoenix Mecano Technologies AG	Stein am Rhein, Switzerland	Finance	CHF	250	100
Phoenix Mecano Beteiligungen AG	Stein am Rhein, Switzerland	Finance	CHF	100	100
Phoenix Mecano Trading AG	Stein am Rhein, Switzerland	Purchasing	CHF	100	100
Phoenix Mecano Komponenten AG	Stein am Rhein, Switzerland	Production/Sales	CHF	2 000	100
Rose Systemtechnik GmbH	Porta Westfalica, Germany	Production/Sales	EUR	1 053	100
Bopla Gehäuse Systeme GmbH	Bünde, Germany	Production/Sales	EUR	750	100
Kundisch GmbH + Co. KG	Villingen-Schwenningen, Germany	Production/Sales	EUR	300	100
Rose Gehäusetechnik GmbH	Eberswalde Finow, Germany	Production	EUR	300	100
Hartmann Codier GmbH	Baiersdorf, Germany	Production/Sales	EUR	300	100
PTR Messtechnik GmbH + Co. KG	Werne, Germany	Production/Sales	EUR	300	100
Götz-Udo Hartmann GmbH + Co. KG	Grävenwiesbach, Germany	Production/Sales	EUR	300	100
Lohse GmbH	Muggensturm, Germany	Production/Sales	EUR	51	100
Datatel Elektronik GmbH	Langenhagen, Germany	Production/Sales	EUR	26	100
RK Rose + Krieger GmbH	Minden, Germany	Production/Sales	EUR	496	100
RK Rose + Krieger GmbH System- & Lineartechnik	Bermatingen, Germany	Production/Sales	EUR	51	100
RK Schmidt Systemtechnik GmbH	Marpingen-Alsweiler, Germany	Production/Sales	EUR	500	90
Dewert Antriebs- und Systemtechnik GmbH	Kirchlengern, Germany	Production/Sales	EUR	1 000	100
Hartmann Elektronik GmbH	Stuttgart, Germany	Production/Sales	EUR	222	100
Plein & Baus GmbH	Burscheid, Germany	Production/Sales	EUR	51	100
Phoenix Mecano Digital Elektronik GmbH	Wutha-Farnroda, Germany	Production/Sales	EUR	350	100
Okin Motion Technologies GmbH	Bergisch Gladbach, Germany	Production/Sales	EUR	25	100
IFINA Beteiligungsgesellschaft mbH	Porta Westfalica, Germany	Finance	EUR	4 000	100
Götz-Udo Hartmann GmbH	Grävenwiesbach, Germany	Finance	EUR	26	100
Kundisch Beteiligungs-GmbH	Villingen-Schwenningen, Germany	Finance	EUR	26	100
PTR Messtechnik Verwaltungs-GmbH	Werne, Germany	Finance	EUR	26	100
Phoenix Mecano S.a.r.l.	Fontenay s/Bois, France	Sales	EUR	620	100
Phoenix Mecano Ltd.	Aylesbury, UK	Sales	GBP	300	100
Phoenix Mecano Finance Ltd.	St. Helier, Channel Islands	Finance	USD	1 969	100
Okin Scandinavia AB	Ingelstad, Sweden	Sales	SEK	100	100
Phoenix Mecano ApS	Odense, Denmark	Sales	DKK	125	100
Phoenix Mecano S.r.l.	Inzago, Milan, Italy	Sales	EUR	300	100
OMP Officina Meccanica di Precisione S.r.l. in liquidation	Milan, Italy	–	EUR	5 000	100
Sistemas Phoenix Mecano España S.A.	Zaragoza, Spain	Sales	EUR	60	90
PM Komponenten B.V.	Doetinchem, The Netherlands	Sales	EUR	20	100
PM International B.V.	Doetinchem, The Netherlands	Finance	EUR	4 500	100
PM Komponenten N.V.	Deinze, Belgium	Sales	EUR	100	100
Phoenix Mecano Kecskemét Kft.	Kecskemét, Hungary	Production/Sales	EUR	5 000	100

## Fully consolidated companies

Company	Head office	Activity	Currency	Registered capital in 1 000	Stake in %
Okin Hungary Gépgyártó Kft.	Hajdúdorog, Hungary	Production	HUF	30 000	100
Phoenix Mecano Plastic S.r.l.	Sibiu, Romania	Production	EUR	750	100
Leonhardy-MCT s.r.l. in Liquidation	Jindřichův Hradec, Czech Republic	–	CZK	1 000	100
Phoenix Mecano Inc.	Frederick, USA	Production/Sales	USD	10 000	100
WIENER Plein & Baus Corp.	Springfield, USA	Sales	USD	100	100
Okin America Inc.	Shannon, USA	Production/Sales	USD	10	100
Phoenix Mecano Comercial e Técnica Ltda.	São Paulo, Brazil	Sales	BRL	5 192	100
Phoenix Mecano S.E. Asia Pte Ltd.	Singapore	Sales	SGD	1 000	75
Phoenix Mecano Korea Co. Ltd.	Seoul, South Korea	Sales	KRW	370 000	75
Phoenix Mecano (India) Ltd.	Pune, India	Production/Sales	INR	272 932	99
Mecano Components (Shanghai) Co. Ltd.	Shanghai, China	Production/Sales	USD	3 925	100
Shenzhen Elcom Trading Co. Ltd.	Shenzhen, China	Purchasing/Sales	CNY	2 000	100
Okin Refined Electric Technology Co., Ltd.	Jiaxing City, China	Production/Sales	CNY	77 780	100
Phoenix Mecano Hong Kong Ltd.	Hong Kong, China	Sales	EUR	500	100
Phoenix Mecano Mazaka AŞ	Ankara, Turkey	Sales	TRY	430	70
Rose Systemtechnik Middle East (FZE)	Sharjah, UAE	Sales	AED	150	100
Phoenix Mecano Australia Pty Ltd.	Tullamarine Victoria, Australia	Sales	AUD	150	70
Hartu S.à.r.l.	Ben Arous, Tunisia	Production	TND	10	100
Phoenix Mecano Hartu S.à.r.l.	Ben Arous, Tunisia	Production	TND	500	100
Phoenix Mecano Tunisie S.à.r.l. in liquidation	Borj-Cedria, Tunisia	–	TND	100	100
Phoenix Mecano ELCOM S.à.r.l.	Djebel El Ouest, Tunisia	Production	TND	500	100
Phoenix Mecano Digital Tunisie S.à.r.l.	Borj-Cedria, Tunisia	Production	TND	100	100

## 3 Goodwill

	2010	2009
1 000 EUR		
<b>Acquisition costs 1 January</b>	<b>1 012</b>	<b>1 336</b>
Change in scope of consolidation	17 635	0
Adjustment of residual purchase price payment as per IFRS 3	0	–324
<b>Acquisition costs 31 December</b>	<b>18 647</b>	<b>1 012</b>
<b>Accumulated impairment losses 1 January</b>	<b>0</b>	<b>0</b>
<b>Accumulated impairment losses 1 January</b>	<b>0</b>	<b>0</b>
<b>Net values 31 December</b>	<b>18 647</b>	<b>1 012</b>

The goodwill of EUR 18.6 million (previous year EUR 1.0 million) relates to the Enclosures (EUR 0.3 million, previous year EUR 0.3 million), ELCOM/EMS (EUR 6.9 million, previous year EUR 0.7 million) and Mechanical Components (EUR 11.4 million, previous year EUR 0.0 million) divisions. The change in goodwill in 2010 is attributable to acquisitions (see note 46). In 2009, this resulted from an adjustment to the contingent residual purchase price liability owing to a revaluation. The

recoverability of this goodwill was tested using five-year plans for the relevant cash-generating units. A pre-tax discount rate (WACC) of 10 % (previous year 10 %; 11 % to measure the goodwill from the acquisition in China) was applied to determine the present value (value in use). Zero growth was assumed after the projection period. The recoverability was also tested using sensitivity analyses.

#### 4 Other intangible assets

	Development costs	Concessions, licences, similar rights and assets	Advance payments and development projects in progress	Total
1 000 EUR				
Note				
<b>Acquisition costs 31 December 2008</b>	<b>14 596</b>	<b>24 744</b>	<b>901</b>	<b>40 241</b>
Change in scope of consolidation 46		2 136		2 136
Translation differences		2		2
Additions	343	645	164	1 152
Disposals	-929	-2 454		-3 383
Reclassification	566	226	-792	0
<b>Acquisition costs 31 December 2009</b>	<b>14 576</b>	<b>25 299</b>	<b>273</b>	<b>40 148</b>
<b>Accumulated amortisation 31 December 2008</b>	<b>12 808</b>	<b>16 876</b>	<b>0</b>	<b>29 684</b>
Translation differences		10		10
Amortisation 37	623	2 834		3 457
Impairment losses 39	627	1 119		1 746
Reversal of impairment losses				0
Disposals	-929	-2 452		-3 381
Reclassification				0
<b>Accumulated amortisation 31 December 2009</b>	<b>13 129</b>	<b>18 387</b>	<b>0</b>	<b>31 516</b>
<b>Net values 31 December 2009</b>	<b>1 447</b>	<b>6 912</b>	<b>273</b>	<b>8 632</b>
<b>Acquisition costs 31 December 2009</b>	<b>14 576</b>	<b>25 299</b>	<b>273</b>	<b>40 148</b>
Additions of companies included in consolidation 46		16 781		16 781
Translation differences		344	-2	342
Additions	198	918	231	1 347
Disposals	-2 419	-270		-2 689
Reclassification	186	56	-242	0
<b>Acquisition costs 31 December 2010</b>	<b>12 541</b>	<b>43 128</b>	<b>260</b>	<b>55 929</b>
<b>Accumulated amortisation 31 December 2009</b>	<b>13 129</b>	<b>18 387</b>	<b>0</b>	<b>31 516</b>
Translation differences		266		266
Amortisation 37	427	3 605		4 032
Impairment losses 39	361	267		628
Reversal of impairment losses				0
Disposals	-2 379	-270		-2 649
Reclassification				0
<b>Accumulated amortisation 31 December 2010</b>	<b>11 538</b>	<b>22 255</b>	<b>0</b>	<b>33 793</b>
<b>Net values 31 December 2010</b>	<b>1 003</b>	<b>20 873</b>	<b>260</b>	<b>22 136</b>

Concessions, licences, similar rights and assets includes primarily the customer base, patents and other industrial property rights as well as unprotected inventions (know-how) gained from acquisitions, in addition to software licences and distribution rights and patents and other intangible rights and assets paid for.

Other intangible assets worth EUR 0.0 million (previous year EUR 0.1 million) were subject to reservation of title as at the balance sheet date.

Write-downs of individual intangible assets, mainly the customer base and development projects, were performed within the framework of the annual impairment tests on cash-generating units (CGUs) and assets at the balance sheet date, since these customers and projects did not develop as originally planned. The five-year plans for the relevant CGU were used as a basis. A pre-tax discount rate (WACC) of 10 % (previous year 10 %) was applied to determine the present value (value in use). A zero growth rate was assumed after the project period.

The breakdown of impairment losses by division is clear from the segment information provided. In the statement of income, impairment losses on intangible assets of EUR 0.6 million (previous year EUR 1.7 million) are included under Other operating expenses (see note 39).

## 5 Tangible assets

		Land and buildings	Machinery and equipment	Advance payments and construction in progress	Total
1 000 EUR	Note				
<b>Acquisition costs 31 December 2008</b>		<b>85 027</b>	<b>164 831</b>	<b>3 826</b>	<b>253 684</b>
Additions of companies included in consolidation	46	1 642	2 268		3 910
Translation differences		141	186	3	330
Additions		2 912	6 635	1 396	10 943
Disposals		-7	-7 164	-90	-7 261
Reclassification		1 908	2 344	-4 252	0
Reclassification of assets held for sale	13	6 276	2		6 278
<b>Acquisition costs 31 December 2009</b>		<b>97 899</b>	<b>169 102</b>	<b>883</b>	<b>267 884</b>
<b>Accumulated depreciation 31 December 2008</b>		<b>34 985</b>	<b>128 551</b>	<b>0</b>	<b>163 536</b>
Translation differences		32	136		168
Depreciation	38	2 810	11 606		14 416
Impairment losses	39	16	665		681
Disposals		-7	-6 899		-6 906
Reclassification					0
Reclassification of assets held for sale	13	4 276			4 276
<b>Accumulated depreciation 31 December 2009</b>		<b>42 112</b>	<b>134 059</b>	<b>0</b>	<b>176 171</b>
<b>Net values 31 December 2009</b>		<b>55 787</b>	<b>35 043</b>	<b>883</b>	<b>91 713</b>
<b>Acquisition costs 31 December 2009</b>		<b>97 899</b>	<b>169 102</b>	<b>883</b>	<b>267 884</b>
Additions of companies included in consolidation	46	15	1 126	120	1 261
Disposals of companies included in consolidation	47	-270	-667		-937
Translation differences		2 605	2 208	10	4 823
Additions		912	11 116	6 268	18 296
Disposals		-269	-5 626	-60	-5 955
Reclassification		108	735	-843	0
<b>Acquisition costs 31 December 2010</b>		<b>101 000</b>	<b>177 994</b>	<b>6 378</b>	<b>285 372</b>
<b>Accumulated depreciation 31 December 2009</b>		<b>42 112</b>	<b>134 059</b>	<b>0</b>	<b>176 171</b>
Disposals of companies included in consolidation	47	-194	-665		-859
Translation differences		981	1 748		2 729
Depreciation	38	2 757	11 035		13 792
Impairment losses	39		116		116
Disposals		-196	-4 977		-5 173
Reclassification					0
<b>Accumulated depreciation 31 December 2010</b>		<b>45 460</b>	<b>141 316</b>	<b>0</b>	<b>186 776</b>
<b>Net values 31 December 2010</b>		<b>55 540</b>	<b>36 678</b>	<b>6 378</b>	<b>98 596</b>

Land and buildings is divided into developed and undeveloped land with a book value of EUR 8.5 million (previous year EUR 9.6 million) and factory and administration buildings with a balance sheet value of EUR 47.0 million (previous year EUR 46.2 million).

The balance sheet value of capitalised leased financial assets (machinery) was EUR 0.1 million, compared with EUR 0.2 million the previous year.

The fire insurance value of the tangible assets amounted to EUR 256.3 million on the balance sheet date compared to EUR 235.0 million the previous year (not including fire insurance value of assets held for sale).

Land and buildings with a book value of EUR 13.6 million (previous year EUR 13.7 million) were mortgaged to cover debts. The amount of the corresponding credit taken up totalled EUR 5.3 million (previous year EUR 5.0 million). Non-current assets to a balance sheet value of EUR 0.1 million (previous year EUR 0.1 million) were subject to reservation of title on the balance sheet date.

Write-downs of individual capital assets or groups of capital assets, mainly for machinery and tools, were performed within the framework of the annual impairment tests on cash-generating units (CGUs) and assets at the balance sheet date. The five-year plans for the corresponding CGUs (product areas and product lines) were used as a basis. A pre-tax discount rate (WACC) of 10 % (previous year 10 %) was applied to determine the present value (value in use). A zero growth rate was assumed after the projection period.

The breakdown by division of impairment losses and reversals of impairment losses is clear from the segment information provided. Impairment losses on tangible assets, amounting to EUR 0.1 million (previous year EUR 0.7 million), are posted under Other operating expenses (see note 39).

## 6 Investments in associated companies

1 000 EUR	Investment %	2010	2009
<b>Update of investment in associated companies</b>			
AVS Phoenix Mecano GmbH, Vienna (A)	50		
<b>As at 1 January</b>		<b>541</b>	<b>668</b>
Result		86	73
Dividends paid		-125	-200
<b>As at 31 December</b>		<b>502</b>	<b>541</b>
<b>Financial figures AVS Phoenix Mecano GmbH</b>			
Non-current assets		0	1
Current assets		1 219	1 353
Liabilities		215	272
Income		3 796	3 439
Expenses		3 624	3 293

Phoenix Mecano products are sold in Austria through the joint venture AVS Phoenix Mecano GmbH (A). Purchases of goods by Group companies totalled EUR 2.6 million (previous year EUR 2.3 million).



## 7 Other financial assets

		2010	2009
1 000 EUR	Note		
Loans		841	1 026
Counter-guarantee requirement for pension obligations		0	691
Investments (under 20 %)		12	12
Non-current securities		275	133
Current portion of long-term financial assets	10	-420	-949
Value adjustments		-696	-839
<b>Balance sheet value</b>		<b>12</b>	<b>74</b>
<b>By currency</b>			
EUR		12	74
<b>Balance sheet value</b>		<b>12</b>	<b>74</b>
<b>By maturity</b>			
in 2 years		0	8
none		12	66
<b>Balance sheet value</b>		<b>12</b>	<b>74</b>
<b>Interest rates (loans)</b>			
EUR		5,9 %	5,1 %

The loans are fixed rate.

The non-current securities in the financial year and the counter-guarantee requirement in the previous year relating to pension obligations are secured with liens in favour of the employees concerned.

Update of value adjustment on other financial assets		2010	2009
1 000 EUR	Note		
<b>As at 1 January</b>		<b>839</b>	<b>1 061</b>
Release of value adjustment (inflow of funds)	40	-60	-222
Release of value adjustment (disposal)		-83	0
<b>As at 31 December</b>		<b>696</b>	<b>839</b>

## 8 Inventories

	2010	2009
1 000 EUR		
Raw and ancillary materials	84 802	57 901
Work in progress	7 062	4 812
Finished goods and merchandise for resale	51 383	38 645
Advance payments	763	521
Value adjustments	-11 716	-13 721
<b>Balance sheet value</b>	<b>132 294</b>	<b>88 158</b>

The value adjustments were determined based on marketability and range of the stocks. Value adjustments and losses on inventories totalling EUR -0.1 million (previous year EUR 3.6 million) are included in the statement of income under Other operating expenses (see note 39). The reduction in value adjustments is due to lower stock risks in the improved economic environment compared with the previous year.

Other than the usual reservations of title applied in typical business operations, no stocks had liens on them as at 31 December 2010 and 2009.

## 9 Trade receivables

	2010	2009
1 000 EUR		
Trade receivables	55 351	50 815
Receivables due from associated companies	90	36
Value adjustments	-3 175	-3 657
<b>Balance sheet value</b>	<b>52 266</b>	<b>47 194</b>
<b>By currency of trade receivables</b>		
CHF	2 013	1 195
EUR	34 803	34 917
USD	5 312	4 295
HUF	151	111
Other currencies	9 987	6 676
<b>Balance sheet value</b>	<b>52 266</b>	<b>47 194</b>
<b>Regional breakdown of trade receivables</b>		
Switzerland	2 350	1 529
Germany	11 348	10 947
UK	2 548	2 519
France	4 081	4 862
Italy	5 206	4 314
Benelux	3 593	3 260
Rest of Europe	7 734	7 009
North and South America	6 631	6 383
Middle and Far East	8 775	6 371
<b>Balance sheet value</b>	<b>52 266</b>	<b>47 194</b>
<b>Update of value adjustment on trade receivables</b>		
<b>Individual value adjustments</b>		
<b>As at 1 January</b>	<b>1 992</b>	<b>1 534</b>
Change	-296	458
<b>As at 31 December</b>	<b>1 696</b>	<b>1 992</b>
<b>Flat-rate value adjustments</b>		
<b>As at 1 January</b>	<b>1 665</b>	<b>1 504</b>
Change	-186	161
<b>As at 31 December</b>	<b>1 479</b>	<b>1 665</b>
<b>Total</b>	<b>3 175</b>	<b>3 657</b>

Aging analysis of trade receivables not subject to individual value adjustments	2010		2009	
	Gross	Value adjustment	Gross	Value adjustment
1 000 EUR				
Gross values	55 441		50 851	
Gross value of receivables subject to individual value adjustments	-1 957		-2 595	
<b>Total</b>	<b>53 484</b>		<b>48 256</b>	
of which:				
Not due	40 888		34 735	
Overdue for 1–30 days	7 766		8 796	
Overdue for 31–60 days	2 549		2 094	
Overdue for 61–90 days	420	91	888	153
Overdue for 91–180 days	562	211	485	254
Overdue for more than 180 days	1 299	1 177	1 258	1 258
<b>Total</b>	<b>53 484</b>	<b>1 479</b>	<b>48 256</b>	<b>1 665</b>

The average payment term was reduced to 45 days (previous year 48 days).

The individual value-adjusted receivables relate mainly to debtors who are involved in bankruptcy proceedings or have been directed to a collection agency. The flat-rate value adjustments for overdue receivables were determined on the basis of experience. There are no cluster risks.

Receivables not due and to which individual value adjustments have not been applied are mainly receivables from long-standing customers. The Phoenix Mecano Group considers the value adjustments formed as appropriate based on past experience.

## 10 Other receivables

		2010	2009
1 000 EUR	Note		
Tax receivables from VAT and other taxes		4 616	3 870
Current portion of long-term financial assets	7	420	949
Financial receivables		1 704	1 049
Other		1 796	1 619
<b>Balance sheet value</b>		<b>8 536</b>	<b>7 487</b>

The financial receivables relate to deposits receivable from agreements providing for part-time work for older employees in Germany, which are listed in EUR, yield an interest rate of 2.5 % and are secured by liens in favour of the employees concerned, and a residual purchase price receivable from the sale of the Group company IPES Industria de Produtos e Equipamentos de Solda Ltda. (see note 47). This receivable is being paid in instalments through to early 2012 and is mortgage-backed.

**11 Current securities**

	2010	2009
1 000 EUR		
<b>Available-for-sale securities</b>		
Shares and equity funds	417	0
Bonds and bond funds	5 858	4 543
<b>Balance sheet value</b>	<b>6 275</b>	<b>4 543</b>
<b>By currency</b>		
CHF	417	0
EUR	5 761	4 427
Other currencies	97	116
<b>Balance sheet value</b>	<b>6 275</b>	<b>4 543</b>
<b>By maturity</b>		
in 1 year	1 407	1 122
in 2 years	1 668	1 035
in 3 years	1 912	1 058
in 4 years	423	856
in 5 years	213	0
after 5 years	54	240
none	598	232
<b>Balance sheet value</b>	<b>6 275</b>	<b>4 543</b>
<b>Effective interest rate for bonds</b>		
EUR	1.9 %	1.8 %
Other currencies	6.0 %	7.0 %

The current securities can be converted into cash and cash equivalents at short notice. They are kept as cash reserves.

## 12 Cash and cash equivalents

	2010	2009
1 000 EUR		
<b>Means of payment</b>		
Cash at bank and in postal accounts	12 184	9 280
Cash on hand and cheques	89	122
<b>Total</b>	<b>12 273</b>	<b>9 402</b>
<b>Other cash and cash equivalents</b>		
Fixed-term deposits (up to 3 months)	19 527	33 191
<b>Balance sheet value</b>	<b>31 800</b>	<b>42 593</b>
<b>By currency</b>		
CHF	1 396	1 254
EUR	20 187	33 493
USD	2 195	2 704
HUF	2 330	978
Other currencies	5 692	4 164
<b>Balance sheet value</b>	<b>31 800</b>	<b>42 593</b>
<b>Interest rates</b>		
CHF	0.1 %	0.2 %
EUR	0.7 %	0.7 %
USD	0.2 %	0.1 %
HUF	4.6 %	0.5 %

## 13 Assets held for sale

The sale of the building in Germany recognised under this item in the previous year was successfully completed in the reporting year for EUR 1.2 million, with corresponding transfer of ownership following receipt of payment.

## 14 Share capital

Pursuant to a decision by the Shareholders' General Meeting of 28 May 2010, the share capital of Phoenix Mecano AG was reduced from CHF 988 000 to CHF 978 000 (CHF is the statutory currency of Phoenix Mecano AG) through the cancellation of 10 000 shares from the 2008/2009 share buyback programme, with effect from 2 September 2010. The share capital is fully paid up and divided into 978 000 bearer shares (previous year 988 000) with a nominal value of CHF 1.00. The conversion into euro is effected at the historical exchange rate of 0.622. There is no authorised or contingent capital.

The principal shareholders of Phoenix Mecano AG are:

		2010	2009
in %			
<b>Name</b>	<b>Head office</b>		
Planalto AG	Luxembourg City, Luxembourg	33.7	33.4
Tweedy, Browne Company LLC	New York, USA	7.9*	7.9*
UBS Fund Management (Switzerland) AG	Basel, Switzerland	< 3.0	3.1
OppenheimerFunds Inc., of which 5.1 %** (previous year*) held by Oppenheimer International Growth Fund, New York	New York, USA	6.1	4.6*
Sarasin Investmentfonds AG	Basel, Switzerland	5.4*	5.4

\* Stake not reported in the year indicated.

\*\* As reported on 10.11.2010.

This information is based on reports by shareholders mentioned above.

## 15 Treasury shares

	Number of shares		Acquisition costs	
	2010	2009	2010	2009
Number/1 000 EUR				
<b>As at 1 January</b>	<b>19 202</b>	<b>79 930</b>	<b>5 290</b>	<b>24 529</b>
Share purchases	1 737	342	644	88
Share sales	-5 480	-1 440	-1 756	-503
Share buybacks (2nd trading line) – 2008/2009	0	21 870	0	4 683
Capital decrease	-10 000	-81 500	-2 399	-23 507
<b>As at 31 December</b>	<b>5 459</b>	<b>19 202</b>	<b>1 779</b>	<b>5 290</b>

A total of 91 500 shares were bought back under the 2007/2008 and 2008/2009 share buyback programmes, of which 81 500 were cancelled in 2009 and 10 000 in 2010.

Detailed information on the purchases and sales effected in 2010 can be found in the notes to the financial statements of Phoenix Mecano AG on page 123 (see note 4).

Treasury share transactions are effected in CHF, the statutory currency of Phoenix Mecano AG. Due to increased exchange-rate fluctuations, capital decreases and sales have been converted to EUR at the historic exchange rates applying at the time of the acquisition of the corresponding treasury shares (previously, the rates used were those obtaining at the time of the capital reduction or sale). The previous year's figures have been adjusted accordingly. A side-by-side presentation is given in the "Treasury shares" column in the statement of changes in equity for the reporting year and the previous year.

## 16 Minority interest

The principal minority interests are:

	2010	2009
in %		
Phoenix Mecano Australia Pty Ltd.	30	30
Phoenix Mecano Mazaka AŞ	30	30
Phoenix Mecano S.E. Asia Pte Ltd. (Singapore)	25	25
Phoenix Mecano Korea Co. Ltd.	25	25
Sistemas Phoenix Mecano España S.A.	10	10
RK Schmidt Systemtechnik GmbH	10	10

## 17 Liabilities from financial leasing

	2010	2009
1 000 EUR		
Note		
<b>Minimum leasing commitments</b>		
Minimum leasing commitments due within 1 year	79	105
Minimum leasing commitments due within 1–5 years	41	120
<b>Total</b>	<b>120</b>	<b>225</b>
less future interest charge	–9	–25
<b>Present value of leasing commitments</b>	<b>111</b>	<b>200</b>
less current portion	–73	–90
<b>Balance sheet value (long-term portion)</b>	<b>38</b>	<b>110</b>
<b>By currency</b>		
EUR	38	110
<b>Balance sheet value (long-term portion)</b>	<b>38</b>	<b>110</b>
<b>By maturity</b>		
in 2 years	38	69
in 3 years	0	41
<b>Balance sheet value</b>	<b>38</b>	<b>110</b>

The average interest rate for liabilities from financial leasing was 8.0 % (previous year 7.8 %).



**18 Other long-term financial liabilities**

1 000 EUR	Note	2010	2009
Liabilities to financial institutions		29 965	28 086
Residual purchase price liabilities from acquisitions		16 507	1 534
Current portion of long-term financial liabilities	24	-12 822	-10 181
<b>Balance sheet value</b>		<b>33 650</b>	<b>19 439</b>
<b>By currency</b>			
CHF		8 812	10 784
EUR		9 372	8 655
USD		82	0
CNY		15 384	0
<b>Balance sheet value</b>		<b>33 650</b>	<b>19 439</b>
<b>By maturity</b>			
in 2 years		8 292	9 640
in 3 years		5 788	4 643
in 4 years		16 868	2 409
in 5 years		2 464	1 273
after 5 years		238	1 474
<b>Balance sheet value</b>		<b>33 650</b>	<b>19 439</b>
<b>Interest rates</b>			
CHF		2.5 %	2.8 %
EUR		3.2 %	4.6 %
USD		3.5 %	n/a
CNY		5.0 %	n/a

For some acquired companies, agreements were made to pay the balance of the purchase price at a later date. These break down as follows: contingent residual purchase price liabilities totalling EUR 1.1 million (previous year EUR 1.5 million) and a purchase obligation resulting from a call and put option totalling EUR 15.4 million. These residual purchase price payments were discounted to the balance sheet date (see note 46).

For the securing of bank liabilities by mortgage, see note 5.

In principle, all liabilities to financial institutions are fixed rate. Two receiver swaps totalling EUR 5.0 million (current portion: EUR 4.0 million) were used to secure variable interest rates (see note 19).

There are no covenants.

## 19 Derivative financial instruments

	Contract values		Receivables due from derivative financial instruments		Liabilities from derivative financial instruments	
	2010	2009	2010	2009	2010	2009
1 000 EUR						
<b>Forward exchange contracts by currency</b>						
CHF	2 403	0	213	0	0	0
USD	1 500	700	249	277	0	0
HUF	16 800	13 800	1 023	881	0	0
RON	5 800	1 200	7	165	54	0
Other currencies	500	206	31	0	0	5
<b>Total</b>	<b>27 003</b>	<b>15 906</b>	<b>1 523</b>	<b>1 323</b>	<b>54</b>	<b>5</b>
<b>Forward exchange contracts by maturity</b>						
in 1 year			1 403	608	30	5
in 2 years			120	715	24	0
<b>Total</b>			<b>1 523</b>	<b>1 323</b>	<b>54</b>	<b>5</b>
of which classified as:						
Cash flow hedge			1 243	1 046	54	0
Trading			280	277	0	5
<b>Total</b>			<b>1 523</b>	<b>1 323</b>	<b>54</b>	<b>5</b>
<b>Interest rate change contracts by currency</b>						
EUR	10 000	16 000	138	448	108	52
CHF	2 403	0	65	0	0	0
<b>Total</b>	<b>12 403</b>	<b>16 000</b>	<b>203</b>	<b>448</b>	<b>108</b>	<b>52</b>
<b>Interest rate change contracts by maturity</b>						
in 1 year			186	347	108	52
in 2 years			17	90	0	0
in 3 years			0	11	0	0
<b>Total</b>			<b>203</b>	<b>448</b>	<b>108</b>	<b>52</b>
of which classified as:						
Fair value hedge			138	448	0	0
Trading			65	0	108	52
<b>Total</b>			<b>203</b>	<b>448</b>	<b>108</b>	<b>52</b>
<b>Net balance sheet value by maturity</b>						
Total long-term			137	816	24	0
Total short-term			1 589	955	138	57
<b>Net balance sheet value</b>			<b>1 726</b>	<b>1 771</b>	<b>162</b>	<b>57</b>

The forward exchange purchases of HUF, RON and CHF for EUR are treated as a cash flow hedge and are used for partial hedging of the planned operating expenses in Hungary and Romania, as well as for the Phoenix Mecano AG dividend payment in 2011. The timing and amounts of future cash flows from forward exchange contracts can be seen in the maturity table in note 28. The corresponding hedges were effective in the reporting period. The other forward exchange contracts in the consolidated financial statements to 31 December 2010 and 31 December 2009 are held for trading purposes.

Two receiver swaps totalling EUR 5 million (previous year EUR 11 million) were used to secure variable interest rates on two underlying fixed-rate loans. These interest rate change contracts in EUR are treated as a fair value hedge. The other interest rate change contracts relate to payer swaps in EUR and CHF and are held for trading purposes in the consolidated financial statements to 31 December 2010 and 31 December 2009.

The balance sheet values of the derivative financial instruments correspond to the fair values.

## 20 Provisions

1 000 EUR	Provisions for long-term employee benefits		Guarantee provisions	Other provisions	2010	2009
	Pension obligations	Other			Total	Total
<b>Provisions as at 1 January</b>	<b>4 802</b>	<b>3 958</b>	<b>3 392</b>	<b>8 062</b>	<b>20 214</b>	<b>17 564</b>
Change in scope of consolidation			24	24	48	473
Translation differences	72	23	52	172	319	85
Usage	-532	-490	-960	-2 964	-4 946	-5 828
Releases	-53	-100	-613	-938	-1 704	-1 275
Reclassification of assets held for sale					0	475
Allocation	354	829	2 030	5 780	8 993	8 630
Reclassification		-20		20	0	0
<b>Provisions as at 31 December</b>	<b>4 643</b>	<b>4 200</b>	<b>3 925</b>	<b>10 156</b>	<b>22 924</b>	<b>20 214</b>
Due within 1 year	367	820	3 825	7 483	12 495	9 283
Due after 1 year	4 276	3 380	100	2 673	10 429	10 931

The provisions for long-term employee benefits relate to pension obligations in Germany and Switzerland (under Pension obligations) as well as to agreements providing for part-time work for older employees in Germany, statutory retirement pay in Italy ("Trattamento Fine Rapporto") and provisions for length-of-service awards (under Other).

Other provisions include provisions for short-term payments to employees (e.g. indemnities and salary bonuses) totalling EUR 5.7 million (previous year EUR 3.7 million), and provisions for lawsuit risks and other conceivable risks or contingent obligations.

## 21 Pension obligations

Financial position of defined benefit pension plans as at 31 December 2010 and 2009		2010	2009
1 000 EUR	Note		
<b>Present value of defined benefit obligations</b>			
<b>As at 1 January</b>		<b>13 732</b>	<b>13 136</b>
Service costs		970	1 013
Interest expense		498	510
Capital		656	279
Pension payments		-1 119	-2 068
Actuarial(gains)/losses		957	821
Translation differences		1 989	41
<b>As at 31 December</b>		<b>17 683</b>	<b>13 732</b>
<b>Market value of plan assets</b>			
<b>As at 1 January</b>		<b>8 422</b>	<b>8 926</b>
Expected return		249	264
Employer contributions		489	457
Employee contributions		435	410
Capital		656	279
Pension payments		-585	-1 881
Actuarial gains/(losses)		-4	-63
Translation differences		1 717	30
<b>As at 31 December</b>		<b>11 379</b>	<b>8 422</b>
<b>Net balance sheet value of pension obligations</b>			
Present value of defined benefit obligations financed using a pension fund		-13 385	-9 367
Fair value of plan assets		11 379	8 422
		-2 006	-945
Present value of defined benefit obligations not financed using a pension fund		-4 298	-4 365
Unrecognised actuarial (gains)/losses		1 661	508
<b>Net balance sheet value of defined benefit plans (provision)</b>	20	<b>-4 643</b>	<b>-4 802</b>

Table continued on page 97.

Table continued from page 96.

	2010	2009	2008	2007	2006
1 000 EUR					
<b>Pension expense</b>					
Service costs	970	1 013			
Interest expense	498	510			
Expected return	-249	-264			
Employee contributions	-435	-410			
<b>Pension expense for defined benefit plans</b>	<b>784</b>	<b>849</b>			
<b>Pension expense for defined contribution plans</b>	<b>363</b>	<b>344</b>			
<b>Pension expense</b>	<b style="color: red;">1 147</b>	<b style="color: red;">1 193</b>			
<b>Actuarial assumptions</b>					
Weighted discount rate	3.2 %	3.9 %			
Expected return on plan assets	2.8 %	3.0 %			
Weighted expected rate of salary increase	1.7 %	1.8 %			
Weighted expected rate of pension increase	0.7 %	0.8 %			
<b>Funding of defined benefit pension obligations</b>					
Plan assets	11 379	8 422	8 926	7 274	7 917
Pension plan obligations	17 683	13 732	13 136	10 539	12 112
<b>Funding difference</b>	<b>-6 304</b>	<b>-5 310</b>	<b>-4 210</b>	<b>-3 265</b>	<b>-4 195</b>
of which recognised in the balance sheet as provisions	-4 643	-4 802	-4 614	-3 612	-3 202
<b>Experience adjustment of plan assets and benefit obligations</b>					
Actuarial and experience adjustment of plan assets	-4	-64	70	154	0
Actuarial and experience adjustment of benefit obligations	-305	-225	-53	978	-70

The expected 2.8 % (previous year 3.0 %) return on plan assets corresponds to the anticipated long-term income derived from the legal minimum interest rate in Switzerland and the surplus from the collective foundation. The actual return on capital tallies more or less with the expected income.

The plan assets relate to the Swiss pension plan and take the form of a repurchase value on the corresponding collective life insurance contract with the insurance provider.

The expected outflow of funds for employer contributions from defined benefit plans in 2011 is EUR 0.5 million.

**Other long-term employee benefits** Provisions for agreements providing for part-time work for older employees in Germany, statutory retirement pay in Italy ("Trattamento Fine Rapporto") and length-of-service awards were set aside in accordance with IAS 19 (see note 20).

**22 Deferred tax**

	2010	2009
1 000 EUR		
<b>Deferred tax assets</b>		
Non-current assets	834	872
Inventories	2 404	1 736
Receivables	353	246
Provisions	1 310	1 084
Other	505	335
<b>Deferred tax assets on temporary differences</b>	<b>5 406</b>	<b>4 273</b>
Deferred tax on losses carried forward	7 807	11 522
<b>Total deferred tax assets</b>	<b>13 213</b>	<b>15 795</b>
Netting with deferred tax liabilities	-2 145	-1 510
Value adjustments on deferred taxes on losses carried forward	-7 129	-11 386
Value adjustments on deferred taxes on non-current assets	-385	-433
Value adjustments on deferred taxes on inventories	-246	-6
Value adjustments on deferred taxes on receivables	-114	-1
Value adjustments on deferred taxes on provisions	-330	-238
Value adjustments on deferred taxes on other	-32	-6
<b>Balance sheet value</b>	<b>2 832</b>	<b>2 215</b>
<b>Deferred tax liabilities</b>		
Non-current assets	-6 224	-4 737
Inventories	-1 101	-1 195
Receivables	-107	-128
Provisions	-64	-103
Other	-303	-252
<b>Total deferred tax liabilities</b>	<b>-7 799</b>	<b>-6 415</b>
Netting with deferred tax assets	2 145	1 510
<b>Balance sheet value</b>	<b>-5 654</b>	<b>-4 905</b>
<b>Net position deferred tax</b>	<b>-2 822</b>	<b>-2 690</b>
<b>Trend of deferred tax</b>		
<b>As at 1 January</b>	<b>-2 690</b>	<b>-3 137</b>
Changes of tax rate recognised in the statement of income	14	48
Translation differences	-52	-17
Change in scope of consolidation	-3 201	191
Reduction/(increase) in value adjustments on fluctuations in fair value of cash flow hedges not affecting income	7	-182
Change in temporary differences recognised in the statement of income	3 100	407
<b>As at 31 December</b>	<b>-2 822</b>	<b>-2 690</b>

Table continued on page 99.

Table continued from page 98.

	2010	2009
<b>Non-capitalised tax losses carried forward</b>		
Up to 1 year	1 325	9 447
1–2 years	4 597	1 380
2–3 years	1 084	4 530
3–4 years	670	1 080
4–5 years	831	207
Over 5 years	21 958	29 005
<b>Total</b>	<b>30 465</b>	<b>45 649</b>

Due to uncertainties regarding the usability of tax losses carried forward totalling EUR 30 million (previous year EUR 46 million), a value adjustment of the resulting tax savings of EUR 7.1 million (previous year EUR 11.4 million) was made on the balance sheet date. The reasons for the net decrease in non-capitalised tax losses carried forward are: use, expiry associated with discontinued operations and the sale of a Group company. Of the tax losses carried forward which expire after five years, EUR 17.1 million (previous year EUR 10.8 million) expire within 20 years. The remaining losses can be carried forward for an indefinite period.

The deferred tax liabilities include deferred tax totalling EUR 0.2 million (previous year EUR 0.2 million) on fluctuations in fair value on cash flow hedges posted without affecting income.

Valuation differences on investments in fully consolidated companies and residual purchase price liabilities from acquisitions on which no deferred tax has been calculated totalled EUR 47.4 million (previous year EUR 45.0 million).

Because no corresponding dividend payments are planned, there was no accrual of deferred tax on undistributed profits of subsidiaries.

### 23 Trade payables

	2010	2009
1 000 EUR		
Trade payables	20 434	15 349
<b>Balance sheet value</b>	<b>20 434</b>	<b>15 349</b>
<b>By currency</b>		
CHF	967	587
EUR	13 309	10 425
USD	2 626	2 466
HUF	270	277
Other currencies	3 262	1 594
<b>Balance sheet value</b>	<b>20 434</b>	<b>15 349</b>

**24 Short-term financial liabilities**

1 000 EUR	Note	2010	2009
Liabilities to financial institutions		15 850	13 529
Residual purchase price liabilities from acquisitions		494	0
Other		10	13
Current portion of:			
Liabilities from financial leasing	17	73	90
Other financial liabilities	18	12 822	10 181
<b>Balance sheet value</b>		<b>29 249</b>	<b>23 813</b>
<b>By currency</b>			
CHF		10 904	6 412
EUR		14 295	15 005
USD		3 916	2 378
Other currencies		134	18
<b>Balance sheet value</b>		<b>29 249</b>	<b>23 813</b>
<b>By maturity</b>			
in < 3 months		17 070	12 423
in 3–6 months		5 934	6 589
in 6–12 months		6 245	4 801
<b>Balance sheet value</b>		<b>29 249</b>	<b>23 813</b>
<b>Interest rates</b>			
CHF		1.8 %	1.1 %
EUR		3.4 %	3.5 %
USD		1.6 %	1.5 %
Other currencies		8.2 %	7.0 %

**25 Other liabilities**

1 000 EUR	2010	2009
Social security liabilities	1 394	1 209
Liabilities to employees	4 788	3 587
Liabilities arising from VAT and other taxes	6 242	4 675
Other	5 636	2 886
<b>Balance sheet value</b>	<b>18 060</b>	<b>12 357</b>



## 26 Categories of financial instruments

As at 31 December 2010 and 31 December 2009, the book values of financial assets and liabilities (including long-term fixed-interest financial liabilities), as shown below, correspond approximately to the IFRS fair value (difference of EUR 0.6 million in both cases).

		2010	2009
1 000 EUR	Note		
Other financial assets	7	12	74
Trade receivables	9	52 266	47 194
Other receivables (excluding VAT and other taxes)	10	3 920	3 617
Cash and cash equivalents (excluding cash on hand)	12	31 711	42 471
<b>Loans and receivables</b>		<b>87 909</b>	<b>93 356</b>
Current securities	11	6 275	4 543
<b>Available-for-sale financial assets</b>		<b>6 275</b>	<b>4 543</b>
Derivative financial instruments (not used for hedging)	19	345	277
<b>Financial assets at fair value through profit or loss</b>		<b>345</b>	<b>277</b>
Liabilities from financial leasing	17	-38	-110
Financial liabilities (excluding residual purchase price liabilities)	18, 24	-45 898	-41 718
Trade payables	23	-20 434	-15 349
Other liabilities (excluding social security, employees, VAT and other taxes)	25	-5 636	-2 886
<b>Liabilities at amortised cost</b>		<b>-72 006</b>	<b>-60 063</b>
Derivative financial instruments (not used for hedging)	19	-108	-57
Residual purchase price liabilities from acquisitions	18, 24	-17 001	-1 534
<b>Financial liabilities at fair value through profit or loss</b>		<b>-17 109</b>	<b>-1 591</b>

The following table classifies the financial assets and liabilities valued at market value according to the three levels of the fair value hierarchy:

		2010	2009	Hierarchy
1 000 EUR	Note			
Financial assets measured at market value:				
Current securities	11	6 275	4 543	Level 1
Derivative financial instruments	19	1 726	1 771	Level 2
<b>Total</b>		<b>8 001</b>	<b>6 314</b>	
Financial liabilities measured at market value:				
Derivative financial instruments	19	-162	-57	Level 2
Residual purchase price liabilities from acquisitions	18, 24	-17 001	-1 534	Level 3
<b>Total</b>		<b>-17 163</b>	<b>-1 591</b>	

The levels of the fair value hierarchy and their application with respect to the relevant assets and liabilities are described as follows:

- Level 1: Quoted market prices in active markets for identical assets or liabilities
- Level 2: Directly or indirectly observable information other than quoted market prices
- Level 3: Information re assets and liabilities which is not based on observable market data

The following table provides an update on Level 3 financial liabilities:

	2010	2009
1 000 EUR		
<b>Balance as at 1 January</b>	<b>1 534</b>	<b>2 317</b>
Additions of companies included in consolidation	15 862	0
Usage	-716	0
Netting with goodwill as per IFRS 3	0	-324
Releases (Other financial income)	0	-507
Allocation (Other financial expense)	271	0
Interest expense	50	48
<b>Balance as at 31 December</b>	<b>17 001</b>	<b>1 534</b>

The residual purchase price liabilities may alter owing to a change in exchange rates (see note 28), a change in the interest rate or a change in the parameters for determining the residual purchase price (see note 46).

## 27 Risk management

The Board of Directors of Phoenix Mecano AG has ultimate responsibility for risk management. To this end it set up the Internal Auditing Department, which is responsible for developing and monitoring compliance with risk management principles. The Internal Auditing Department reports regularly to the Audit Committee of the Phoenix Mecano AG Board of Directors.

The risk management principles that have been established are geared towards identifying and analysing the risks to which the Group is exposed, developing checks and balances and monitoring risks. The risk management principles and the processes associated with them are regularly reviewed to take account of changes in market conditions and the Group's activities.

## 28 Financial risk management

**General** The Phoenix Mecano Group is exposed to various financial risks through its business activities, namely credit risk, market risk (i.e. currency and interest rate risks) and liquidity risk. Currency and interest rate risks are managed centrally at Group level. Financial instruments, of which only limited use is made – almost exclusively for hedging purposes – are also controlled centrally. In view of this centralised currency management, exchange rate differences are shown in the financial result.

The management of non-essential cash and cash equivalents and the Group's financing is also centrally controlled.

The Phoenix Mecano Group invests in securities. The investment instruments it uses are bonds, bond funds, shares and equity funds. These investments are diversified and internal limits are applied to individual investment categories. The investments are conducted principally in EUR and CHF.

The following sections give an overview of specific financial risks, their magnitude, the aims, principles and processes involved in measuring, monitoring and hedging them, and the Group's capital management.

**Credit risk** Credit risk is the risk of incurring financial loss when a counterparty to a financial instrument fails to meet its contractual obligations. Credit risks are most likely to be associated with long-term loans, trade receivables and investments in debt securities (e.g. bonds) and cash or cash equivalents. The Group minimises the credit risk associated with cash and cash equivalents by only doing business with reputable financial institutions and by dealing with a range of such institutions rather than just one. Investments in debt securities must be investment grade (this usually means a rating of at least BBB). They are suitably diversified in order to minimise risk.

To reduce the risk associated with trade receivables, customers are subject to internal credit limits. Because the customer structure varies from one division to the next, there are no general credit limits applying throughout the Phoenix Mecano Group. Creditworthiness is reviewed regularly according to internal guidelines. Credit limits are set based on financial situation, previous experience and other factors. The Group's extensive customer base, which covers a variety of regions and sectors, means that the credit risk on receivables is limited. There are no cluster risks.

The maximum credit risk on financial instruments corresponds to the book values of the individual financial assets. There are no guarantees or similar obligations that could cause the risk to exceed book values. The maximum credit risk on the balance sheet date was:

		2010	2009
1 000 EUR	Note		
Other financial assets	7	12	74
Derivative financial instruments	19	1 726	1 771
Trade receivables	9	52 266	47 194
Other receivables (excluding tax receivables from VAT and other taxes)	10	3 920	3 617
Current securities	11	6 275	4 543
Cash and cash equivalents (excluding cash on hand)	12	31 711	42 471
<b>Total</b>		<b>95 910</b>	<b>99 670</b>

**Liquidity risk** Liquidity risk is the risk that the Phoenix Mecano Group will be unable to meet its financial obligations when these become due.

The Phoenix Mecano Group monitors its liquidity risk by means of careful liquidity management. In so doing, its guiding principle is to make available a cash reserve exceeding daily and monthly operational funding requirements. Given the dynamic business environment in which it operates, the Group's aim is to preserve the necessary flexibility of financing, ensuring that it has sufficient unused credit lines with financial institutions and retains its ability to procure funds on the capital market. The credit lines are divided up among several financial institutions. As at 31 December 2010, unused credit lines with major banks totalled EUR 49.4 million (previous year EUR 42.2 million).

### Maturity analysis as at 31 December 2010

	Book value	Outflow of funds	in < 3 months	in 3–6 months	in 6–12 months	in 1–5 years	in > 5 years
1 000 EUR							
<b>Non-derivative financial instruments</b>							
Trade payables	20 434	-20 434	-19 883	-347	-204		
Other liabilities (excluding social security, employees, VAT and other taxes)	5 636	-5 636	-5 636				
Financial liabilities (excluding financial leasing)	62 826	-66 897	-17 224	-6 295	-6 550	-36 582	-246
Liabilities from financial leasing (long- and short-term)	111	-120	-20	-19	-40	-41	
<b>Total</b>	<b>89 007</b>	<b>-93 087</b>	<b>-42 763</b>	<b>-6 661</b>	<b>-6 794</b>	<b>-36 623</b>	<b>-246</b>
<b>Derivative financial instruments</b>							
<b>Interest rate swap classified as:</b>							
Fair value hedge	-138	138		87	34	17	
Trading	43	-43	-43				
<b>Forward exchange transaction classified as:</b>							
Cashflow hedge: outflow of funds		-25 003	-3 100	-5 703	-7 400	-8 800	
Cashflow hedge: inflow of funds	-1 189	26 192	3 347	6 140	7 809	8 896	
Trading: outflow of funds		-2 000	-2 000				
Trading: inflow of funds	-280	2 280	2 280				
<b>Total</b>	<b>87 443</b>	<b>-91 523</b>	<b>-42 279</b>	<b>-6 137</b>	<b>-6 351</b>	<b>-36 510</b>	<b>-246</b>

**Maturity analysis as at 31 December 2009**

	Book value	Outflow of funds	in < 3 months	in 3–6 months	in 6–12 months	in 1–5 years	in > 5 years
1 000 EUR							
<b>Non-derivative financial instruments</b>							
Trade payables	15 349	–15 349	–15 139	–84	–126		
Other liabilities (excluding social security, employees, VAT and other taxes)	2 886	–2 886	–2 886				
Financial liabilities (excluding financial leasing)	43 162	–45 212	–11 845	–7 682	–5 196	–18 987	–1 502
Liabilities from financial leasing (long- and short-term)	200	–225	–29	–32	–43	–121	
<b>Total</b>	<b>61 597</b>	<b>–63 672</b>	<b>–29 899</b>	<b>–7 798</b>	<b>–5 365</b>	<b>–19 108</b>	<b>–1 502</b>
<b>Derivative financial instruments</b>							
<b>Interest rate swap classified as:</b>							
Fair value hedge	–448	448		216	131	101	
Trading	52	–52	–52				
<b>Forward exchange transaction classified as:</b>							
Cashflow hedge: outflow of funds		–15 000	–2 550	–2 550	–5 100	–4 800	
Cashflow hedge: inflow of funds	–1 046	16 046	2 654	2 641	5 236	5 515	
Trading: outflow of funds		–900	–900				
Trading: inflow of funds	–272	1 172	1 172				
<b>Total</b>	<b>59 883</b>	<b>–61 958</b>	<b>–29 575</b>	<b>–7 491</b>	<b>–5 098</b>	<b>–18 292</b>	<b>–1 502</b>

Contingent liabilities (see note 30) represent a potential outflow of funds.

**Market risk** Market risk is the risk that changes in market prices such as exchange rates, interest rates and share prices will have an effect on the earnings and fair value of the financial instruments held by Phoenix Mecano. The aim of market risk management is to monitor and control such risks, thereby ensuring that they do not exceed a certain level.

**Currency risk** Although it generates 65 % of its sales in the euro area (previous year 64 %) and a significant portion of its expenditure is in EUR, the Phoenix Mecano Group operates internationally and is therefore exposed to a foreign currency risk. Aside from EUR, transactions are conducted principally in CHF, USD, HUF and CNY. Foreign currency risks arise from expected future transactions and from assets and liabilities recorded in the balance sheet, where these are not in the functional currency of the respective Group company. To hedge such risks from expected future transactions, the Phoenix Mecano Group enters into forward exchange contracts with reputable counterparties as and when necessary, or uses foreign currency options. This hedging relates mainly to planned expenditure in local currency (in companies whose functional currency is not the same as the local currency) at major production locations – primarily Hungary – and occasionally in USD, CHF, GBP and AUD, with hedges declining as a proportion of the planned currency exposure the further ahead the transaction is due to take place. The extent of the items to be hedged is reviewed regularly. Such hedges cover a maximum period of three years. The Group realises both income and expenditure in USD and aims to minimise the resulting currency exposure primarily by means of operational measures (alignment of income and expenditure flows).

Financing from financial institutions is mainly in EUR, CHF and USD and is recorded by Group companies in the relevant functional currency. An exception to this is a USD financing arrangement relating to Phoenix Mecano AG. In the financial year, there was also a residual purchase price liability from acquisitions in CNY at a subsidiary that draws up its balance sheet in EUR.

The following tables set out the currency risks associated with financial instruments, where the currency differs from the functional currency of the Group company holding the instruments:

#### Currency risk as at 31 December 2010

Non-derivative financial instruments	EUR	CHF	USD	HUF	CNY
1 000 EUR					
Trade receivables	2 971	0	588	140	0
Cash and cash equivalents	1 740	48	566	2 142	0
Trade payables	-157	-56	-1 391	219	0
Financial liabilities	0	0	-3 828	0	-15 384
<b>Total</b>	<b>4 554</b>	<b>-8</b>	<b>-4 095</b>	<b>2 063</b>	<b>-15 384</b>
Forward exchange transactions	0	0	- 1 749	0	0
<b>Net risk</b>	<b>4 554</b>	<b>-8</b>	<b>-5 844</b>	<b>2 063</b>	<b>-15 384</b>

**Currency risk as at 31 December 2009**

Non-derivative financial instruments	EUR	CHF	USD	HUF
1 000 EUR				
Trade receivables	2 888	0	117	111
Cash and cash equivalents	1 914	14	909	948
Trade payables	-145	-30	-1 040	-195
Financial liabilities	0	0	-2 094	0
<b>Total</b>	<b>4 657</b>	<b>-16</b>	<b>-2 108</b>	<b>864</b>
Forward exchange transactions	0	0	-977	0
<b>Net risk</b>	<b>4 657</b>	<b>-16</b>	<b>-3 085</b>	<b>864</b>

Based on the above-mentioned currency risks, the following sensitivity analysis for the main currency pairs shows how the result of the period would be affected if the exchange rates were to alter by 10 %. All other variables, in particular interest rates, are assumed to remain unchanged. Significantly greater effects on the statement of income may arise from price movements relating to ongoing foreign currency transactions during the financial year.

**Sensitivity analysis for 2010 and 2009**

Sensitivity analysis	CHF/EUR	CHF/USD	EUR/USD	EUR/HUF	EUR/CNY
1 000 EUR					
<b>2010: Change in result of the period (approx.)</b>	<b>95</b>	<b>218</b>	<b>76</b>	<b>206</b>	<b>1 620</b>
2009: Change in result of the period (approx.)	174	206	51	85	n/a

On 31 December 2010, equity would have been EUR 1.9 million (previous year EUR 1.2 million) lower if the exchange rate had been 10 % higher and EUR 2.4 million (previous year EUR 1.4 million) higher if the exchange rate had been 10 % lower, on account of forward exchange contracts classified as cash flow hedges.

**Interest rate risk** Interest rate risk is divided up into an interest cash flow risk, i.e. the risk that future interest payments will change due to fluctuations in the market interest rate, and an interest-related risk of a change in the market value, i.e. the risk that the market value of a financial instrument will change due to fluctuations in the market interest rate. The Group's interest-bearing financial assets and liabilities are primarily cash and cash equivalents and current securities, as well as liabilities to financial institutions. The Group uses interest rate options and swaps to hedge and/or structure external debts. (In addition, it partially hedges interest rate risks on financial assets.)

**Sensitivity analysis for 2010 and 2009** The Phoenix Mecano Group is exposed to an interest cash flow risk with respect to variable-rate liquid funds and variable-rate liabilities to financial institutions. If the interest rates on variable-rate liabilities excluding fixed-term deposits had been 50 basis points higher or lower, the result of the period for 2010 and 2009 would have been less than EUR 0.1 million lower or higher, assuming all other variables had remained constant.

The impact on equity of a 50-basis point change in interest rates, given the bonds classified as financial assets held for sale at 31 December 2010 or 31 December 2009, would have been less than EUR 0.1 million, assuming all other variables had remained constant.

## 29 Capital management

The aims of capital management are to safeguard the Phoenix Mecano Group as a going concern, thereby ensuring continued income for shareholders and providing other stakeholders with the benefits to which they are entitled. In addition, the Group seeks to preserve scope for future growth and acquisitions by means of conservative financing.

To this end, the Group aims to maintain a long-term equity ratio of at least 40 %. The dividend policy of the Phoenix Mecano Group specifies a payout ratio of 15–25 % of sustainable net profit (20–30 % as from 2011). Capital increases should be avoided as far as possible in order to prevent profit dilution. Where appropriate, the Group uses share buybacks as a means of adjusting its capital structure and reducing capital costs.

The Phoenix Mecano Group monitors its capital management based on its gearing, i.e. the ratio of net indebtedness to equity. Net indebtedness consists of total interest-bearing liabilities (including residual purchase price liabilities from acquisitions) less current securities and cash and cash equivalents.

Net indebtedness as at 31 December 2010 and 31 December 2009 was as follows:

1 000 EUR	Note	2010	2009
Liabilities from financial leasing	17	38	110
Other long-term financial liabilities	18	33 650	19 439
Short-term financial liabilities	24	29 249	23 813
<b>Interest-bearing liabilities</b>		<b>62 937</b>	<b>43 362</b>
less current securities	11	6 275	4 543
less cash and cash equivalents	12	31 800	42 593
<b>Net indebtedness (previous year: Net liquidity)</b>		<b>24 862</b>	<b>-3 774</b>
Equity		236 226	193 365
<b>Gearing</b>		<b>10.5 %</b>	

The increase in net indebtedness in 2010 was due in part to the increased residual purchase price liabilities relating to acquisitions.



### 30 Contingent liabilities

	2010	2009
1 000 EUR		
Sureties and guarantees	751	894
Commitments from bills of exchange	19	24
<b>Total</b>	<b>770</b>	<b>918</b>

### 31 Commitments to purchase tangible assets

The purchase commitment for tangible assets as at 31 December 2010 was EUR 5.5 million (previous year EUR 1.0 million).

### 32 Operating leases, rent and leasehold rent

	2010	2009
1 000 EUR		
Minimum commitments due within 1 year	2 636	2 492
Minimum commitments due within 1–5 years	5 859	4 857
Minimum commitments due after 5 years	5 164	5 335
<b>Minimum operating leasing, rent and leasehold rent commitments</b>	<b>13 659</b>	<b>12 684</b>
Minimum claims due within 1 year	50	87
Minimum claims due within 1–5 years	0	47
<b>Minimum claims from rent/leasehold rent</b>	<b>50</b>	<b>134</b>

The operating leasing, rent and leasehold rent commitments consist almost exclusively of commitments for leased premises and floor space (long-term lease).

### 33 Gross sales

	2010	2009
1 000 EUR		
Gross sales	501 558	396 913
<b>Total</b>	<b>501 558</b>	<b>396 913</b>

The gross sales shown include invoiced goods and services supplied by the Group to third parties and associated companies. Value-added taxes, directly granted rebates and discounts and credit notes for returns have been deducted.

Gross sales were up by 26.4 % compared to prior year (previous year: down by 4.9 %). Differences in foreign exchange rates and changes to the scope of consolidation affected gross sales by 2.3 % and 1.9 % respectively (previous year –0.1 % and 13.8 % respectively).

**34 Other operating income**

	2010	2009
1 000 EUR		
Reimbursement from insurance	684	1 030
Gains on the disposal of intangible and tangible assets	212	206
Government subsidies	160	179
Other	3 552	3 384
<b>Total</b>	<b>4 608</b>	<b>4 799</b>

**35 Cost of materials**

	2010	2009
1 000 EUR		
Cost of raw and ancillary materials, merchandise for resale and external services	241 141	187 820
Incidental acquisition costs	9 087	7 158
<b>Total</b>	<b>250 228</b>	<b>194 978</b>

Value adjustments and losses on inventories are posted under Other operating expenses (see note 39).

**36 Personnel expenses**

	2010	2009
1 000 EUR		
Wages and salaries	105 532	92 706
Social costs	21 933	19 575
Supplementary staff costs	4 198	3 320
<b>Total</b>	<b>131 663</b>	<b>115 601</b>

**37 Amortisation of intangible assets**

	2010	2009
1 000 EUR		
Concessions, licences, similar rights and assets	3 605	2 834
Development services	427	623
<b>Total</b>	<b>4 032</b>	<b>3 457</b>

**38 Depreciation on tangible assets**

1 000 EUR	2010	2009
Land and buildings	2 757	2 810
Machinery and equipment	11 035	11 606
<b>Total</b>	<b>13 792</b>	<b>14 416</b>

**39 Other operating expenses**

1 000 EUR	Note	2010	2009
External development costs		564	413
Establishment expenses		19 061	15 654
Rent, leasehold rent, leases		3 909	3 570
Administration expenses		7 118	6 412
Advertising expenses		3 086	3 290
Sales expenses		16 219	12 322
Losses from the disposal of intangible and tangible assets		280	114
Impairment losses on intangible and tangible assets	4, 5	744	2 487
Losses and value adjustments on inventories	8	-118	3 617
Capital and other taxes		833	1 577
Other		5 569	6 201
<b>Total</b>		<b>57 265</b>	<b>55 657</b>

Total development costs, including internal costs, amounted to EUR 5.4 million (previous year EUR 6.1 million).

**40 Financial income**

1 000 EUR	Note	2010	2009
Interest income from third parties		670	524
Fair value hedge gain (on underlying transaction)	19	310	89
Gain from financial assets at fair value through profit or loss (trading derivative)	19	86	292
Exchange rate gains		2 568	2 304
Value adjustment on financial assets	7	60	222
Other financial income		533	771
<b>Total</b>		<b>4 227</b>	<b>4 202</b>

**41 Financial expenses**

		2010	2009
1 000 EUR	Note		
Interest expense		1 183	1 383
Fair value hedge loss (from derivative financial instruments)	19	310	89
Loss from financial assets at fair value through profit or loss (trading derivative)	19	69	35
Exchange rate losses		3 200	1 950
Loss from disposal of Group companies	47	528	0
Other financial expense		768	498
<b>Total</b>		<b>6 058</b>	<b>3 955</b>

The increase under Other financial expense is primarily due to a revaluation of the residual purchase price liabilities from acquisitions.

**42 Income tax**

		2010	2009
1 000 EUR			
Current income tax		10 077	2 718
Deferred tax		-3 114	-455
<b>Income tax</b>		<b>6 963</b>	<b>2 263</b>
<b>Reconciliation from theoretical to effective income tax:</b>			
<b>Result before tax</b>		<b>50 847</b>	<b>13 863</b>
<b>Theoretical income tax</b>		<b>12 221</b>	<b>1 645</b>
<b>Weighted income tax rate</b>	in %	<b>24.0</b>	<b>11.9</b>
Changes of tax rate deferred tax		-14	-48
Tax-free income		-106	-244
Non-deductible expenses		1 498	654
Tax effect on losses in the reporting year		173	974
Tax effect of losses carried forward from previous years		-1 158	-65
Income tax relating to other periods		-5 226	-632
Other		-425	-21
<b>Effective income tax</b>		<b>6 963</b>	<b>2 263</b>
<b>Effective income tax rate</b>	in %	<b>13.7</b>	<b>16.3</b>

The theoretical income taxes are derived from the weighted current local tax rates in the countries where the Phoenix Mecano Group does business. The heavy fluctuation in the weighted theoretical income tax rate is explained by fact that countervailing results at the individual subsidiaries are subject to different local tax rates.

The income from income tax relating to other periods in 2010 and 2009 resulted largely from the disappearance of tax risks from earlier tax periods.

In addition to the deferred taxes presented above, EUR 0.0 million (previous year EUR –0.2 million) in deferred tax expenses linked to fluctuations in the fair value of cash flow hedges posted without affecting income were offset directly against equity (see note 22).

### 43 Earnings per share

	2010	2009
1 000 EUR		
<b>Result</b>		
<b>Result of the period attributable to shareholders of the parent company</b>	<b>43 635</b>	<b>11 505</b>
<b>Number of shares</b>		
Shares issued on 1 January	988 000	1 069 500
Capital decrease	–10 000	–81 500
Treasury shares (annual average)	–8 224	–17 173
<b>Shares outstanding</b>	<b>969 776</b>	<b>970 827</b>
<b>Basis for diluted earnings per share</b>	<b>969 776</b>	<b>970 827</b>
<b>Basis for undiluted earnings per share</b>	<b>969 776</b>	<b>970 827</b>

### 44 Operating cash flow

		2010	2009
1 000 EUR	Note		
Operating result		52 592	13 543
Amortisation of intangible assets	37	4 032	3 457
Depreciation on tangible assets	38	13 792	14 416
<b>Operating cash flow</b>		<b>70 416</b>	<b>31 416</b>

### 45 Free cash flow

		2010	2009
1 000 EUR			
Cash flow from operating activities		29 361	46 718
Purchases of intangible assets		–1 347	–1 152
Purchases of tangible assets		–18 296	–10 943
Disinvestments in intangible assets		40	2
Disinvestments in tangible assets		1 915	448
<b>Free cash flow (before financial investments)</b>		<b>11 673</b>	<b>35 073</b>

#### 46 Acquisition of Group companies

The acquired assets and assumed liabilities break down as follows (2010: provisional):

	2010	2009
1 000 EUR	Fair value	Fair value
Customer base	4 930	1 439
Other intangible assets	11 851	697
Tangible assets	1 261	3 910
Other non-current assets	0	191
Other current assets	5 806	18 930
Cash and cash equivalents	2 067	867
Liabilities	-6 707	-5 071
<b>Identifiable net assets</b>	<b>19 208</b>	<b>20 963</b>
Goodwill/(negative goodwill) from acquisition	17 635	-272
<b>Purchase price</b>	<b>-36 843</b>	<b>-20 691</b>
Residual purchase price liability	15 862	0
Cash and cash equivalents acquired	2 067	867
<b>Change in funds</b>	<b>-18 914</b>	<b>-19 824</b>

On 1 May 2010, the Phoenix Mecano Group acquired full ownership of Lohse GmbH, Muggensturm (D), a leading manufacturer of special toroidal strip-wound cores, strip-wound cut cores and air-gap cores, whose applications include transformers and chokes for solar inverters. The acquisition provides Phoenix Mecano with key expertise and boosts its competitiveness and innovative capacity in the increasingly important growth segment of photovoltaics. Part of the purchase price (EUR 0.5 million) is dependent on future business development and will not be paid until 2011 or 2012. The figures for this acquisition have been adjusted compared with the provisional figures (Goodwill/Other intangible assets/Deferred tax/Residual purchase price liabilities) given in the 2010 semi-annual report.

With effect from 22 November 2010, the Phoenix Mecano Group acquired a 90 % stake in the newly founded joint venture Okin Refined Electric Technology Co. Ltd. based in Jiaxing City, China. The company will take over the development, production and sale of electrical linear drives for the furniture and care industry in the Asian market and parts of the North American market. A call and put option has been agreed for the remaining 10 % of the shares, to take effect at the beginning of 2014 at the earliest. The contractual agreement for the residual payment is based on an EBITDA multiple with no upper limit. As at the balance sheet date, this commitment was measured at EUR 15.4 million on a discounted basis.

The acquired receivables totalling EUR 1.6 million were fully paid in accordance with expectations at the acquisition date.

The acquired companies generated consolidated gross sales of EUR 3.0 million in 2010 and their contribution to the Phoenix Mecano Group's result of the period was EUR 0.4 million. Had all companies been consolidated since 1 January 2010, consolidated gross sales would have totalled EUR 518.1 million and consolidated result of the period EUR 45.6 million.

In the previous year, under an asset deal effective from 1 January 2009, the Phoenix Mecano Group acquired the business operations of Eiden & Schmidt GmbH Messtechnik. As part of the first-time consolidation, a capital increase took place, in which the minority shareholder took a 10 % stake. Under an asset deal effective from 5 February 2009, the Phoenix Mecano Group acquired the drive solutions business for comfort and office furniture of insolvent company Okin Antriebstechnik GmbH (D). These business operations are now being run under the name Okin Motion Technologies GmbH (D). As part of the transaction, 100 % of the shares in production and sales companies in Hungary, the USA and Sweden were also acquired. The acquired companies had gross sales of EUR 58.0 million in 2009 (of which Okin companies accounted for EUR 56.9 million), and their contribution to the Phoenix Mecano Group's result of the period was EUR –7.3 million (Okin companies EUR –6.6 million). Had all companies been consolidated since 1 January 2009, consolidated gross sales would have totalled EUR 404.3 million and consolidated result of the period EUR 11.0 million.

#### 47 Disposal of Group companies

	2010	2009
1 000 EUR		
Tangible assets	78	0
Other current assets	536	0
Cash and cash equivalents	17	0
Liabilities	–62	0
	<b>569</b>	<b>0</b>
Translation differences	932	0
Loss from disposal of Group companies	–528	0
<b>Purchase price</b>	<b>973</b>	<b>0</b>
of which outstanding residual purchase price	331	0
<b>paid as at balance sheet date</b>	<b>642</b>	<b>0</b>
Disposal of cash and cash equivalents	–17	0
<b>Change in funds</b>	<b>625</b>	<b>0</b>

On 26 August 2010, the Group sold 100 % of the shares in IPES Industria de Produtos e Equipamentos de Solda Ltda. Consolidated gross sales in 2010 totalled EUR 1.6 million.

#### 48 Transactions with related parties

	2010	2009
1 000 EUR		
Chairman of the Board of Directors	95	86
Delegate of the Board of Directors	806	385
Other members of the Board of Directors	93	85
<b>Remuneration of the Board of Directors</b>	<b>994</b>	<b>556</b>
<b>Remuneration of the Executive Committee</b> (excluding the Delegate of the Board of Directors)	<b>2 209</b>	<b>1 663</b>
<b>Remuneration of the Board of Directors and Executive Committee</b>	<b>3 203</b>	<b>2 219</b>
Social security contributions	200	159
Pension obligations	207	187
<b>Total remuneration of the Board of Directors and Executive Committee</b>	<b>3 610</b>	<b>2 565</b>

Transactions with associated companies are presented in notes 6, 9 and 23.

The remuneration of the Executive Committee in the reporting year includes the pro-rata annual remuneration of the new Chief Operating Officer and Chairman designate of the Executive Committee, Dr Rochus Kobler, who joined the Group on 1 September 2010.

Detailed information on transactions with related parties is provided in the notes to the financial statements of Phoenix Mecano AG on page 127 (see note 19).

No significant transactions with other related parties outside the scope of consolidation took place in 2010 or 2009.

#### 49 Events after the balance sheet date

Tunisia, an important production location for the Group, experienced short-term disruptions to the production and logistics chain in early 2011 due to the collapse of the regime of former president Ben Ali. Production and supply conditions are now largely back to normal as far as Phoenix Mecano is concerned, so from today's perspective there is unlikely to be any material impact on the 2011 accounts.

No other events occurred between 31 December 2010 and 25 March 2011 that would alter the book values of assets and liabilities or should be disclosed under this heading.

#### 50 Approval of the consolidated financial statements

At its meeting on 25 March 2011, the Board of Directors of Phoenix Mecano AG released the 2010 consolidated financial statements for publication. These will be submitted to the Shareholders' General Meeting on 27 May 2011 with a recommendation for their approval.

#### 51 Dividend and capital decrease

The Board of Directors recommends to the Shareholders' General Meeting of 27 May 2011 that a dividend of CHF 13.00 (CHF is the statutory currency of Phoenix Mecano AG) per share be paid out (see Proposal for the appropriation of retained earnings on page 130). The total outflow of funds is expected to be CHF 12.7 million. The dividend paid out in 2010 was CHF 10.00 (previous year CHF 10.00) per share. The outflow of funds in 2010 was CHF 9.7 million (previous year CHF 9.8 million).



# REPORT OF THE STATUTORY AUDITOR

## ON THE CONSOLIDATED FINANCIAL STATEMENTS

### **To the Shareholders' General Meeting of Phoenix Mecano AG, Stein am Rhein**

As statutory auditor, we have audited the accompanying consolidated financial statements of Phoenix Mecano AG, presented on pages 56 to 116, which comprise the consolidated balance sheet, consolidated income statement, consolidated statement of comprehensive income, consolidated cash flow statement, consolidated statement of changes in equity, and notes for the year ended 31 December 2010.

### **Board of Directors' responsibility**

The Board of Directors is responsible for the preparation and fair presentation of the consolidated financial statements in accordance with International Financial Reporting Standards (IFRS) and the requirements of Swiss law. This responsibility includes designing, implementing and maintaining an internal control system relevant to the preparation and fair presentation of consolidated financial statements that are free from material misstatement, whether due to fraud or error. The Board of Directors is further responsible for selecting and applying appropriate accounting policies and making accounting estimates that are reasonable in the circumstances.

### **Auditor's responsibility**

Our responsibility is to express an opinion on these consolidated financial statements based on our audit. We conducted our audit in accordance with Swiss law and Swiss Auditing Standards as well as International Standards on Auditing. Those standards require that we plan and perform the audit to obtain reasonable assurance whether the consolidated financial statements are free from material misstatement.

An audit involves performing procedures to obtain audit evidence about the amounts and disclosures in the consolidated financial statements. The procedures selected depend on the auditor's judgment, including the assessment of the risks of material misstatement of the consolidated financial statements, whether due to fraud or error. In making those risk assessments, the auditor considers the internal control system relevant to the entity's preparation and fair presentation of the consolidated financial statements in order to design audit procedures that are appropriate in the circumstances, but not for the purpose of expressing an opinion on the effectiveness of the entity's internal control system. An audit also includes evaluating the appropriateness of the accounting policies used and the reasonableness of accounting estimates made, as well as evaluating the overall presentation of the consolidated financial statements. We believe that the audit evidence we have obtained is sufficient and appropriate to provide a basis for our audit opinion.

### **Opinion**

In our opinion, the consolidated financial statements for the year ended 31 December 2010 give a true and fair view of the financial position, the results of operations and the cash flows in accordance with International Financial Reporting Standards (IFRS) and comply with Swiss law.

### **Report on other legal requirements**

We confirm that we meet the legal requirements on licensing according to the Auditor Oversight Act (AOA) and independence (Article 728 CO and Article 11 AOA) and that there are no circumstances incompatible with our independence.

In accordance with Article 728a paragraph 1 item 3 CO and Swiss Auditing Standard 890, we confirm that an internal control system exists, which has been designed for the preparation of consolidated financial statements according to the instructions of the Board of Directors.

We recommend that the consolidated financial statements submitted to you be approved.

KPMG AG

Roger Neininger  
Licensed audit expert  
Auditor in charge

Thomas Lehner  
Licensed audit expert

Zurich, 25 March 2011

# FIVE-YEAR OVERVIEW

	2010	2009	2008	2007	2006
1 000 EUR					
<b>Consolidated balance sheet</b>					
<b>Total</b>	381 433	301 100	294 042	287 643	263 724
<b>Non-current assets</b>	142 864	105 003	106 482 <sup>1</sup>	98 500 <sup>1</sup>	97 013 <sup>1</sup>
in % of total assets	37.5	34.9	36.2	34.2	36.8
Tangible assets	98 596	91 713	90 148 <sup>1</sup>	89 331 <sup>1</sup>	87 055 <sup>1</sup>
<b>Current assets</b>	238 571	196 097	187 560 <sup>1</sup>	189 143 <sup>1</sup>	166 711 <sup>1</sup>
in % of total assets	62.5	65.1	63.8	65.8	63.2
Inventories	132 294	88 158	90 889 <sup>1</sup>	86 059 <sup>1</sup>	78 111 <sup>1</sup>
Cash and cash equivalents	31 800	42 593	39 155	42 381	24 677
<b>Equity</b>	236 226	193 365	191 045	182 515	166 942
in % of total assets	61.9	64.2	65.0	63.5	63.3
<b>Liabilities</b>	145 207	107 735	102 997	105 128	96 782
in % of total assets	38.1	35.8	35.0	36.5	36.7
<b>Net indebtedness</b>	24 862	-3 774	2 275	4 288	12 957
in % of equity	10.5	-2.0	1.2	2.3	7.8
<b>Consolidated statement of income</b>					
<b>Gross sales</b>	501 558	396 913	417 261	389 382	351 495
<b>Gross sales from continued operations</b>	n/a	n/a	n/a	n/a	346 506
<b>Total operating performance</b>	509 572	397 652	417 866	390 529 <sup>2</sup>	347 192 <sup>2</sup>
<b>Personnel expenses</b>	131 663	115 601	119 898	112 231 <sup>2</sup>	104 121 <sup>2</sup>
<b>Amortisation of intangible assets</b>	4 032	3 457	2 752	1 763 <sup>2</sup>	2 189 <sup>2</sup>
<b>Depreciation on tangible assets</b>	13 792	14 416	13 767	14 559 <sup>2</sup>	13 744 <sup>2</sup>
<b>Result before interest and tax (operating result)</b>	52 592	13 543	42 789	38 800	35 810 <sup>2</sup>
<b>Financial result</b>	-1 745	320	-3 550	-1 775 <sup>2</sup>	-4 603 <sup>2</sup>
<b>Result before tax</b>	50 847	13 863	39 239	37 025 <sup>2</sup>	31 207 <sup>2</sup>
<b>Income tax</b>	6 963	2 263	8 640	7 080 <sup>2</sup>	4 258 <sup>2</sup>
<b>Result of the period from continued operations</b>	43 884	11 600	30 599	29 945	26 949
<b>Result of the period from discontinued operations</b>	n/a	n/a	-16	13 <sup>3</sup>	855 <sup>3</sup>
<b>Result of the period</b>	43 884	11 600	30 583	29 958	27 804
in % of gross sales	8.7	2.9	7.3	7.7	7.9
in % of equity	18.6	6.0	16.0	16.4	16.7
<b>Consolidated statement of cash flow</b>					
<b>Cash flow from operating activities</b>	29 361	46 718	47 642	38 807	25 457
<b>Cash used in investing activities</b>	-36 081	-33 870	-20 138	-10 439	4 497
Purchases of tangible assets	18 296	10 943	15 936	16 338	19 371
<b>Cash flow from financing activities</b>	-5 093	-9 632	-30 579	-10 556	-40 024
<b>Free cash flow</b>	11 673	35 073	29 895	21 677	12 233

<sup>1</sup> The assets held for sale are posted in current assets under a separate item.

<sup>2</sup> The figures refer to continued operations, i.e. without the discontinued OMP product area.

<sup>3</sup> Discontinued operations relate to the customised switchgear cabinets and electronic packaging solutions business (OMP product area).

PHOENIX MECANO AG FINANCIAL REPORT 2010

PHOENIX MECANO AG ENDED FINANCIAL YEAR 2010 WITH  
AN ANNUAL PROFIT OF CHF 12 259 533.

GLOBAL. FLEXIBLE. DYNAMIC.

**120 PHOENIX MECANO AG FINANCIAL REPORT 2010**

121 Balance sheet 122 Statement of income 123 Notes to the financial statements 130 Proposal for the appropriation of retained earnings 131 Report of the statutory auditor on the financial statements

## BALANCE SHEET AS AT 31 DECEMBER 2010

PHOENIX MECANO AG

CHF	Note	2010	2009
<b>Assets</b>			
<b>Non-current assets</b>			
<b>Financial assets</b>			
Investments	1	155 962 339	155 159 548
Loans to Group companies	2	18 394 305	11 849 972
<b>Total non-current assets</b>		<b>174 356 644</b>	<b>167 009 519</b>
<b>Current assets</b>			
<b>Receivables</b>			
Financial receivables from Group companies	3	2 536 087	5 436 743
Other receivables	4	1 356 172	985
		<b>3 892 260</b>	<b>5 437 728</b>
Treasury shares	5	2 093 412	6 565 942
Cash and cash equivalents		698 165	2 319 599
<b>Total current assets</b>		<b>6 683 836</b>	<b>14 323 269</b>
<b>Total assets</b>		<b>181 040 480</b>	<b>181 332 788</b>

Equity and liabilities		2010	2009
<b>Equity</b>			
Share capital	6	978 000	988 000
Statutory reserves		2 500 000	2 500 000
Reserve for treasury shares	7	2 793 770	8 333 657
Special reserves		88 994 949	88 994 949
Retained earnings	8	55 233 869	50 735 166
<b>Total equity</b>		<b>150 500 588</b>	<b>151 551 773</b>
<b>Liabilities</b>			
Provisions	9	4 584 300	4 500 000
<b>Long-term liabilities</b>			
Bank loans	10	6 500 000	11 500 000
<b>Short-term liabilities</b>			
Bank liabilities	10	16 408 000	12 605 000
Financial liabilities to Group companies	11	2 505 195	572 467
Liabilities to shareholders		13 464	12 763
Other liabilities		29 171	103 660
		<b>18 955 830</b>	<b>13 293 889</b>
Deferred income		499 761	487 126
<b>Total liabilities</b>		<b>30 539 892</b>	<b>29 781 016</b>
<b>Total equity and liabilities</b>		<b>181 040 480</b>	<b>181 332 788</b>

## STATEMENT OF INCOME 2010

PHOENIX MECANO AG

		2010	2009
CHF	Note		
<b>Income</b>			
Income from investments	13	11 876 299	25 072 852
Financial income	14	2 567 712	1 614 609
Other income	15	1 352 574	31 453
<b>Total income</b>		<b>15 796 585</b>	<b>26 718 913</b>
<b>Expenses</b>			
Financial expenses	16	-642 010	-1 086 983
Administration expenses		-1 267 488	-882 379
Other expenses	17	-1 642 159	-356 553
Income and capital taxes		14 606	-77 381
<b>Total expenses</b>		<b>-3 537 052</b>	<b>-2 403 296</b>
<b>Profit for the year</b>		<b>12 259 533</b>	<b>24 315 617</b>

# NOTES TO THE FINANCIAL STATEMENTS 2010

## GENERAL

The 2010 financial statements for Phoenix Mecano AG in Swiss francs have been drawn up in accordance with the provisions of Swiss corporation law.

### 1 Investments

The following list shows all investments directly held by Phoenix Mecano AG:

Company	Head office	Activity	Currency	Registered capital in 1 000	Investment in %
Phoenix Mecano Management AG	Kloten, Switzerland	Finance	CHF	50	100
Phoenix Mecano Technologies AG	Stein am Rhein, Switzerland	Finance	CHF	250	100
Phoenix Mecano Beteiligungen AG	Stein am Rhein, Switzerland	Finance	CHF	100	100
Phoenix Mecano Trading AG	Stein am Rhein, Switzerland	Purchasing	CHF	100	100
Phoenix Mecano Komponenten AG	Stein am Rhein, Switzerland	Production/Sales	CHF	2 000	100
Phoenix Mecano Finance Ltd.	St. Helier, Channel Islands	Finance	USD	1 969	100
PM International B.V.	Doetinchem, The Netherlands	Finance	EUR	4 500	100
AVS Phoenix Mecano GmbH	Vienna, Austria	Sales	EUR	40	1
Phoenix Mecano Inc.	Frederick, USA	Production/Sales	USD	10 000	100
WIENER Plein & Baus Corp.	Springfield, Ohio, USA	Sales	USD	100	100
Phoenix Mecano S.E. Asia Pte Ltd.	Singapore	Sales	SGD	1 000	75
Phoenix Mecano (India) Ltd.	Pune, India	Production/Sales	INR	272 932	99
Mecano Components (Shanghai) Co. Ltd.	Shanghai, China	Production/Sales	USD	3 925	100
Shenzhen Elcom Trading Co. Ltd.	Shenzhen, China	Purchasing/Sales	CNY	2 000	100
Phoenix Mecano Hong Kong Ltd.	Hong Kong, China	Sales	EUR	500	100
Phoenix Mecano Comercial e Técnica Ltda.	São Paulo, Brazil	Sales	BRL	5 192	100

The change in the balance sheet value compared with the previous year is due to the establishment of Phoenix Mecano Hong Kong Ltd. and the purchase of minority interests in Phoenix Mecano (India) Ltd. The company IPES Industria de Produtos e Equipamentos de Solda Ltda. was sold in the reporting year.

An overview of all directly and indirectly held investments is given on pages 79 and 80.

### 2 Loans to Group companies

This item includes long-term loans in CHF, EUR and USD to subsidiaries in Switzerland and abroad.

### 3 Financial receivables from Group companies

This item comprises short-term financial receivables (including balances on clearing accounts) in CHF, EUR and USD from subsidiaries in Switzerland and abroad.

### 4 Other receivables

This item comprises a purchase price receivable with an equivalent value of CHF 1.4 million from the sale of IPES Industria de Produtos e Equipamentos de Solda Ltda., which is being paid in instalments through to January 2012.

## 5 Treasury shares

Between 2007 and 2009, 58 500 and 33 000 shares were bought back under two share buy-back programmes. Pursuant to a decision by the Shareholders' General Meeting of 5 June 2009, 81 500 bought-back shares were cancelled and the share capital reduced accordingly. Pursuant to a decision by the Shareholders' General Meeting of 28 May 2010, the remaining 10 000 shares bought back in 2009 were cancelled and the share capital reduced accordingly. Consequently, there are no longer any shares remaining from these buyback programmes.

The following is an overview of the purchases and sales of treasury shares made during the reporting year:

	Share purchases		Share sales	
	Number	Average price	Number	Average price
CHF				
January			102	455.45
February	300	455.40		
March	830	464.04	430	505.88
April			374	537.53
May	63	540.00	189	557.93
June	50	540.00		
July			800	569.00
August	71	605.68		
September	114	595.61	1 500	625.10
October	50	638.50	35	635.00
November			2 050	646.20
December	259	628.28		
<b>Total year</b>	<b>1 737</b>	<b>511.43</b>	<b>5 480</b>	<b>604.06</b>

At the balance sheet date, the company owned a total of 5 459 treasury bearer shares (previous year 19 202), which are booked according to the strict lower-of-cost-or-market principle. These shares represent 0.6 % of the overall share portfolio.

## 6 Share capital

Pursuant to a decision by the Shareholders' General Meeting of 28 May 2010, the share capital was reduced from CHF 988 000 to CHF 978 000 through the cancellation of 10 000 shares with a par value of CHF 1.00 each from the 2008/2009 share buyback programme, with effect from 2 September 2010. The share capital was then redivided into 978 000 bearer shares with a par value of CHF 1.00 each.



As at the balance sheet date, major shareholders held the following stakes in the share capital of Phoenix Mecano AG:

Significant shareholders	2010	2009
in %		
Planalto AG, Luxembourg	33.7	33.4
Tweedy, Browne Company LLC, New York	7.9*	7.9*
UBS Fund Management (Switzerland) AG, Basel	< 3	3.1
OppenheimerFunds Inc., New York of which 5.1 %** (previous year*) held by Oppenheimer International Growth Fund, New York	6.1	4.6*
Sarasin Investmentfonds AG, Basel	5.4*	5.4

\* Stake not reported in the year indicated.

\*\* As reported on 10.11.2010.

This information is based on reports by shareholders mentioned above.

## 7 Reserve for treasury shares

Articles 659a (2) and 671a of the Swiss Code of Obligations state that the company must set aside an amount equivalent to the cost of acquiring its own shares as a separate reserve. In 2010, this reserve for treasury shares was reduced by CHF 5 539 887.

## 8 Retained earnings

Financial year 2010 closed with a profit for the year of CHF 12 259 533. The retained earnings brought forward from the previous year totalled CHF 41 048 167. Taking into account the release of the reserve for treasury shares totalling CHF 5 539 887 (see note 7) and the CHF 3 613 718 charge represented by the difference between the par value and balance sheet value of the treasury shares cancelled as part of the capital decrease, the Shareholders' General Meeting of 27 May 2011 has at its disposal retained earnings totalling CHF 55 233 869. For the Board of Directors' proposal regarding the appropriation of retained earnings, see page 130.

## 9 Provisions

As in the previous year, this item comprises provisions to cover investment risks totalling CHF 3.5 million as well as provisions to cover exchange rate risks totalling CHF 1.0 million. There is also a provision of CHF 0.1 million for a legal dispute in Brazil.

## 10 Bank loans/bank liabilities

Long-term bank loans covers financing in CHF. As at 31 December 2010, there were two CHF 2.5 million loans due for repayment in 2012 and one CHF 1.5 million loan due in 2013. The short-term bank liabilities include CHF and USD loans.

**11 Financial liabilities to Group companies**

This item comprises short-term financial liabilities (including liabilities on clearing accounts) in CHF and EUR to subsidiaries in Switzerland and abroad.

**12 Contingent liabilities**

	2010	2009
1 000 CHF		
Guarantees and letters of comfort	131 896	128 381

Contingent liabilities are given for subsidiaries, predominantly in favour of financial institutions. The actual book value of Group company liabilities was CHF 30.0 million (previous year CHF 34.0 million).

In addition, Phoenix Mecano AG has entered into a joint guarantee with its Swiss subsidiaries for the purposes of registration for Group VAT taxation.

**13 Income from investments**

Income from investments comprises dividends paid by subsidiaries in Switzerland and abroad.

**14 Financial income**

Financial income includes earnings from interest and commissions as well as gains from the sale of and appreciation in the value of treasury shares totalling CHF 1.6 million (previous year CHF 0.4 million).

**15 Other income**

As in the previous year, other income in the reporting year includes income from licences. It also includes gains from the disposal of financial assets totalling CHF 1.3 million in the reporting year.

**16 Financial expense**

This item comprises interest and securities expenses.

**17 Other expenses**

This item includes expenses for licences in the reporting year and the previous year, as well as net exchange rate losses of CHF 1.6 million (CHF 2.8 million of exchange rate losses less CHF 1.2 million of exchange rate gains) in the reporting year and CHF 0.3 million in the previous year.

**18 Net release of hidden reserves**

As in the previous year, the statement of income contains no net release of hidden reserves.

## 19 Remuneration and participations

Remuneration of members of the Board of Directors and Executive Committee.

The following remuneration was awarded to serving corporate officers in 2010:

Name	Position	Fixed remuneration	Variable remuneration	Social security and pension	Total remuneration 2010
		1 000 CHF	1 000 CHF	1 000 CHF	1 000 CHF
Ulrich Hocker	Chairman of the Board	130		11	141
Benedikt A. Goldkamp	Delegate of the Board	472	640	148	1 260
Dr Florian Ernst	Board member	43		3	46
Dr Martin Furrer	Board member	43		3	46
Beat Siegrist	Board member	43		3	46
<b>Remuneration of the Board of Directors</b>		<b>731</b>	<b>640</b>	<b>168</b>	<b>1 539</b>
<b>Remuneration of the Executive Committee</b> (excluding the Delegate of the Board of Directors)		<b>2 011</b>	<b>1 037</b>	<b>393</b>	<b>3 441</b>
<b>Total remuneration of the Board of Directors and Executive Committee</b>		<b>2 742</b>	<b>1 677</b>	<b>561</b>	<b>4 980</b>

The following remuneration was awarded to serving corporate officers in 2009:

Name	Position	Fixed remuneration	Variable remuneration	Social security and pension	Total remuneration 2009
		1 000 CHF	1 000 CHF	1 000 CHF	1 000 CHF
Ulrich Hocker	Chairman of the Board	130		11	141
Benedikt A. Goldkamp	Delegate of the Board	472	109	132	713
Dr Florian Ernst	Board member	43		3	46
Dr Martin Furrer	Board member	43		3	46
Beat Siegrist	Board member	43		3	46
<b>Remuneration of the Board of Directors</b>		<b>731</b>	<b>109</b>	<b>152</b>	<b>992</b>
<b>Remuneration of the Executive Committee</b> (excluding the Delegate of the Board of Directors)		<b>1 849</b>	<b>662</b>	<b>369</b>	<b>2 880</b>
<b>Total remuneration of the Board of Directors and Executive Committee</b>		<b>2 580</b>	<b>771</b>	<b>521</b>	<b>3 872</b>

Mr Benedikt A. Goldkamp is also CEO of the Phoenix Mecano Group. His remuneration as CEO is included in his overall remuneration as Delegate of the Board of Directors, the highest individual remuneration of any member of the management (Executive Committee).

The remuneration of the Executive Committee in the reporting year includes the pro-rata annual remuneration of the new Chief Operating Officer and Chairman designate of the Executive Committee, Dr Rochus Kobler, who joined the Group on 1 September 2010.

The variable remuneration is based on individual employment contracts and annual bonus agreements. The amount depends on the attainment of income and return-on-capital targets and in individual cases on personal performance targets. It includes the variable remuneration for the financial year accounted for under (accrued) expenses in the relevant financial statements. For the most part, payments are made subsequent to the balance sheet preparation; the variable remuneration actually paid may vary from the amounts set aside.

Social security and pension comprises employer contributions to social security and staff pension funds as well as allocations to pension provisions.

As in the previous year, no remuneration was paid in the reporting year to former corporate officers who left the company in previous years.

The members of the Board of Directors and Executive Committee received no other remuneration or fees for additional services to the Phoenix Mecano Group.

No loans or securities were awarded to members of the Board of Directors or the Executive Committee or persons related to them.

Share ownership by members of the Board of Directors and Executive Committee and persons related to them:

Name	Position	31.12.2010	31.12.2009
<b>Board of Directors</b>			
Ulrich Hocker	Chairman	8 654	8 624
Benedikt A. Goldkamp	Delegate	1 845	1 820
Dr Florian Ernst	Member	10	10
Dr Martin Furrer	Member	100	100
Beat Siegrist	Member	400	400
<b>Shares held by the Board of Directors</b>		<b>11 009</b>	<b>10 954</b>
<b>Executive Committee</b>			
Ralph Gamper	Member	180	330
Maximilian Kleinle	Member	0	50
Dr Joachim Metzger	Member	55	91
René Schöffeler	Member	80	80
<b>Shares held by the Executive Committee</b>		<b>315</b>	<b>551</b>

In addition, Planalto AG, Luxembourg, which is owned by the Goldkamp family, holds a 33.7 % stake (previous year 33.4 %).

Related persons and companies are considered to be family members as well as any individuals or companies capable of being significantly influenced.

Aside from the remuneration awarded to the Board of Directors and the Executive Committee and the standard contributions to pension funds, no significant transactions with related persons or companies took place.

## **20 Risk management**

The company is covered by the risk management policy of the Phoenix Mecano Group. The Board of Directors of Phoenix Mecano AG has ultimate responsibility for risk management. To this end it set up the Internal Auditing Department, which is responsible for developing and monitoring compliance with risk management principles. The Internal Auditing Department reports regularly to the Audit Committee of the Phoenix Mecano AG Board of Directors. The risk management principles that have been established are geared towards identifying and analysing the risks to which the Group is exposed, developing checks and balances and monitoring risks. The specific risks facing the Phoenix Mecano AG have also been identified. Risk management principles and the processes associated with them are regularly reviewed to take account of changes in market conditions and the Group's activities.

More information on risk management in the Phoenix Mecano Group can be found in the notes to the consolidated financial statements.

## **21 Events after the balance sheet date**

No events occurred between 31 December 2010 and 25 March 2011 that would alter the book values of Phoenix Mecano AG's assets and liabilities or should be disclosed under this heading.

There are no further matters requiring disclosure under Article 663b of the Swiss Code of Obligations.

## PROPOSAL FOR THE APPROPRIATION OF RETAINED EARNINGS

	CHF
Net income for the year 2010	12 259 533
Retained earnings brought forward 2009	41 048 167
Difference between par value and balance sheet value of treasury shares in connection with capital decrease	-3 613 718
Release of reserve for treasury shares	5 539 887
<b>Retained earnings</b>	<b>55 233 869</b>

The Board of Directors proposes to the Shareholders' General Meeting that retained earnings should be distributed as follows:

	CHF
Dividend of CHF 13.00 per share <sup>1</sup>	12 714 000
Carried forward to new account	42 519 869
<b>Total</b>	<b>55 233 869</b>

<sup>1</sup> Total dividends are calculated based on the 978 000 bearer shares. Dividends will not be paid on treasury shares held by the company at the time of the payout.

# REPORT OF THE STATUTORY AUDITOR

## ON THE FINANCIAL STATEMENTS

### **To the Shareholders' General Meeting of Phoenix Mecano AG, Stein am Rhein**

As statutory auditor, we have audited the financial statements of Phoenix Mecano AG, presented on pages 121 to 129, which comprise the balance sheet, income statement and notes for the year ended 31 December 2010.

### **Board of Directors' responsibility**

The Board of Directors is responsible for the preparation of the financial statements in accordance with the requirements of Swiss law and the company's articles of incorporation. This responsibility includes designing, implementing and maintaining an internal control system relevant to the preparation of financial statements that are free from material misstatement, whether due to fraud or error. The Board of Directors is further responsible for selecting and applying appropriate accounting policies and making accounting estimates that are reasonable in the circumstances.

### **Auditor's responsibility**

Our responsibility is to express an opinion on these financial statements based on our audit. We conducted our audit in accordance with Swiss law and Swiss Auditing Standards. Those standards require that we plan and perform the audit to obtain reasonable assurance whether the financial statements are free from material misstatement.

An audit involves performing procedures to obtain audit evidence about the amounts and disclosures in the financial statements. The procedures selected depend on the auditor's judgment, including the assessment of the risks of material misstatement of the financial statements, whether due to fraud or error. In making those risk assessments, the auditor considers the internal control system relevant to the entity's preparation of the financial statements in order to design audit procedures that are appropriate in the circumstances, but not for the purpose of expressing an opinion on the effectiveness of the entity's internal control system. An audit also includes evaluating the appropriateness of the accounting policies used and the reasonableness of accounting estimates made, as well as evaluating the overall presentation of the financial statements. We believe that the audit evidence we have obtained is sufficient and appropriate to provide a basis for our audit opinion.

### **Opinion**

In our opinion, the financial statements for the year ended 31 December 2010 comply with Swiss law and the company's articles of incorporation.

### **Report on other legal requirements**

We confirm that we meet the legal requirements on licensing according to the Auditor Oversight Act (AOA) and independence (Article 728 CO and Article 11 AOA) and that there are no circumstances incompatible with our independence.

In accordance with Article 728a paragraph 1 item 3 CO and Swiss Auditing Standard 890, we confirm that an internal control system exists, which has been designed for the preparation of financial statements according to the instructions of the Board of Directors.

We further confirm that the proposed appropriation of available earnings complies with Swiss law and the company's articles of incorporation. We recommend that the financial statements submitted to you be approved.

KPMG AG

Roger Neininger  
Licensed audit expert  
Auditor in charge

Thomas Lehner  
Licensed audit expert

Zurich, 25 March 2011



INTERNATIONAL PRESENCE

WE ARE A GLOBAL COMPANY OFFERING  
A COMPREHENSIVE RANGE OF SERVICES IN ALL  
MAJOR GROWTH REGIONS.

GLOBAL. FLEXIBLE. DYNAMIC.

# LOCATIONS AROUND THE WORLD

PHOENIX MECANO GROUP

## North | South America

- 1 – 4** USA:  
 Frederick, Maryland (1)  
 Shannon, Mississippi (2)  
 Springfield, Ohio (3)  
 Ontario, California (4)
- 5** Brazil:  
 São Paulo

## Europe | Africa

- 6** Austria: Vienna
- 7 – 8** Benelux:  
 Deinze, Belgium (7)  
 Doetinchem, The Netherlands (8)
- 9** France: Fontenay sur Bois
- 10** Germany:  
 Baiersdorf, Bermatingen,  
 Bünde, Burscheid, Eberswalde,  
 Grävenwiesbach, Kirchlegern,  
 Langenhagen, Marpingen,  
 Minden, Muggensturm,  
 Porta Westfalica, Stuttgart,  
 Villingen-Schwenningen,  
 Werne, Wutha-Farnroda
- 11** Great Britain: Aylesbury
- 12** Hungary: Kecskemét
- 13** Italy: Inzago, Milan
- 14** Romania: Sibiu
- 15** Russia: Moscow
- 16 – 17** Scandinavia:  
 Odense, Denmark (16)  
 Ingelstad, Sweden (17)
- 18** Spain: Zaragoza
- 19** Switzerland: Stein am Rhein
- 20** Tunisia:  
 Ben Arous, Borj-Cedria,  
 Djebel El Ouest-Zaghuan
- 21** Turkey: Ankara

## Asia

- 22** India: Pune
- 23** Korea (South Korea): Seoul
- 24 – 27** People's Republic of China:  
 Hong Kong (24)  
 Jiaxing (25)  
 Shanghai (26)  
 Shenzhen (27)
- 28** Singapore: Singapore
- 29** Taiwan: Taipei
- 30** Thailand: Bangkok
- 31** United Arab Emirates:  
 Sharjah

## Australia

- 32** Australia: Tullamarine, Victoria



North | South America



## ADDRESSES

## Group headquarters

## Switzerland

Phoenix Mecano AG  
Hofwisenstrasse 6  
CH-8260 Stein am Rhein  
www.phoenix-mecano.com

## Finance and service companies

## Switzerland

Phoenix Mecano Management AG  
Lindenstrasse 23  
CH-8302 Kloten  
Phone +41/43/255 42 55  
Fax +41/43/255 42 56  
info@phoenix-mecano.com  
www.phoenix-mecano.com

## Phoenix Mecano Trading AG

Hofwisenstrasse 6  
CH-8260 Stein am Rhein  
Phone +41/52/742 75 22  
Fax +41/52/742 75 92  
pm.trading@phoenix-mecano.com

## Channel Islands GB

Phoenix Mecano Finance Ltd.  
17. Bond Street  
St. Helier  
Jersey, Channel Islands JE2 3NP  
Phone +44/1534/732 299  
Fax +44/1534/725 376

## Germany

IFINA Beteiligungsgesellschaft mbH  
Erbeweg 13-15  
D-32457 Porta Westfalica  
Phone +49/571/504 11 14  
Fax +49/571/504 171 14

## The Netherlands

PM International B.V.  
Havenstraat 100  
NL-7005 AG Doetinchem  
Phone +31/314/368 368  
Fax +31/314/368 378  
ger.hartman@phoenix-mecano.com

## Enclosures

## Germany

Bopla Gehäuse Systeme GmbH  
Borsigstrasse 17-25  
D-32257 Bünde  
Phone +49/5223/969 0  
Fax +49/5223/969 100  
info@bopla.de  
www.bopla.de

## Kundisch GmbH + Co. KG

Steinkirchring 56  
D-78056 Villingen-Schwenningen  
Phone +49/7720/976 10  
Fax +49/7720/976 122  
vertrieb@kundisch.de  
www.kundisch.de

## Rose Systemtechnik GmbH

Erbeweg 13-15  
D-32457 Porta Westfalica  
Phone +49/571/504 10  
Fax +49/571/504 11 59  
rose@rose-pw.de  
www.rose-pw.de

## ELCOM/EMS

## Germany

Datatel Elektronik GmbH  
Am Pferdemarkt 61 A  
D-30853 Langenhagen  
Phone +49/511/90 89 08  
Fax +49/511/604 20 46  
info@datatel.de  
www.datatel.de

## Götz-Udo Hartmann GmbH + Co. KG

Auf der Struth 1  
D-61279 Grävenwiesbach  
Phone +49/6086/961 40  
Fax +49/6086/259  
info@hartu.de  
www.hartu.de

## Hartmann Codier GmbH

Industriestrasse 3  
D-91083 Baiersdorf  
Phone +49/9133/779 30  
Fax +49/9133/42 35  
info@hartmann-codier.de  
www.hartmann-codier.de

## Hartmann Elektronik GmbH

Motorstrasse 43  
D-70499 Stuttgart (Weilimdorf)  
Phone +49/711/139 89-0  
Fax +49/711/866 11 91  
info@hartmann-elektronik.de  
www.hartmann-elektronik.de

## Phoenix Mecano Digital Elektronik GmbH

Am Schunkenhofe 1  
D-99848 Wutha-Farnroda  
Phone +49/36921/20 10  
Fax +49/36921/20 123  
info@pmd-wutha.de  
www.pmd-wutha.de

## Plein &amp; Baus GmbH

Müllersbaum 20  
D-51399 Burscheid  
Phone +49/2174/67 80  
Fax +49/2174/67 855  
plein@wiener-d.com  
www.wiener-d.com

## PTR Messtechnik GmbH + Co. KG

Gewerbehof 38  
D-59368 Werne  
Phone +49/2389/798 80  
Fax +49/2389/798 888  
info@ptr-messtechnik.de  
www.ptr-messtechnik.de

**Mechanical Components****Germany**

**Dewert Antriebs- und Systemtechnik GmbH**  
Weststrasse 1  
D-32278 Kirchlegern  
Phone +49/5223/979 0  
Fax +49/5223/751 82  
info@dewert.de  
www.dewert.de

**Okin Motion Technologies GmbH**

Friedrich-Ebert-Strasse im Campus 1  
D-51429 Bergisch Gladbach  
Phone +49/2204/480 220  
Fax +49/2204/480 221 18  
info@okin.de  
www.okin.de

**RK Rose + Krieger GmbH**

Potsdamer Strasse 9  
D-32423 Minden  
Phone +49/571/933 50  
Fax +49/571/933 51 19  
info@rk-online.de  
www.rk-rose-krieger.com

**Production and sales companies****Australia**

**Phoenix Mecano Australia Pty Ltd.**  
64 Butler Way  
Tullamarine  
Victoria 3043  
Phone +61/3/933 856 99  
Fax +61/3/933 853 99  
info@dewert.com.au  
www.dewert.com.au

**Austria**

**AVS Phoenix Mecano GmbH**  
Birostrasse 17  
A-1230 Vienna  
Phone +43/1/615 08 01  
Fax +43/1/615 080 11 30  
info@avs-phoenix.at  
www.avs-phoenix.at

**Benelux**

**PM Komponenten N.V.**  
Karrewegstraat 124  
B-9800 Deinze  
Phone +32/9/220 70 50  
Fax +32/9/220 72 50  
info.pmb@phoenix-mecano.com  
www.pmkomponenten.be

**PM Komponenten B.V.**

Havenstraat 100  
NL-7005 AG Doetinchem  
Phone +31/314/368 368  
Fax +31/314/368 378  
info.pmnl@phoenix-mecano.com  
www.pmkomponenten.nl

**Brazil**

**Phoenix Mecano Comercial e Técnica Ltda.**  
Av. Prof. Alceu Maynard de Araújo, 185  
BR-04726-160 São Paulo  
Phone +55/11/564 341 90  
Fax +55/11/564 108 82  
vendas@phoenix-mecano.com.br  
www.phoenixmecano.com.br

**France**

**Phoenix Mecano S.à.r.l.**  
76, rue du Bois-Galon  
F-94121 Fontenay sur Bois, Cedex  
Phone +33/1/539 950 50  
Fax +33/1/539 950 76  
info.pmf@phoenix-mecano.com  
www.phoenixmecano.fr

**Germany**

**Lohse GmbH**  
Heinkelstrasse 12  
D-76461 Muggensturm  
Phone +49/7222/8 22 95  
Fax +49/7222/5 14 44  
info@lohse-ringbandkerne.de  
www.lohse-ringbandkerne.de

**Rose Gehäusetechnik GmbH**

Schönholzer Strasse 18  
D-16227 Eberswalde  
Phone +49/3334/309 80  
Fax +49/3334/309 822  
www.rose-eberswalde.de

**RK Rose + Krieger GmbH**

**System- & Lineartechnik**  
Salerstrasse 55  
D-88697 Bermatingen  
Phone +49/7544/962 20  
Fax +49/7544/9 622 79  
info@rk-sl.de  
www.rk-sl.de

**RK Schmidt Systemtechnik GmbH**

Feldstrasse 21  
D-66646 Marpingen-Alsweiler  
Phone +49/6853/91 36 0  
Fax +49/6853/91 36 22  
info@rk-schmidt.de  
www.rk-schmidt.de

**Great Britain**

**Phoenix Mecano Ltd.**  
Unit 26 Faraday Road  
Aylesbury  
GB-Buckinghamshire HP19 8RY  
Phone +44/1296/61 16 60  
Fax +44/1296/48 62 96  
info@phoenix-mecano.com  
www.phoenix-mecano.co.uk

**Hungary**

**Phoenix Mecano Kecskemét Kft.**  
István kir. krt. 24  
H-6000 Kecskemét  
Phone +36/76/515 500  
Fax +36/76/515 555  
info@phoenix-mecano.hu  
www.phoenix-mecano.hu

**India**

**Phoenix Mecano (India) Ltd.**  
388 Bhare, Pirangut Industrial Area  
Mulshi, Pune 412 108  
Phone +91/20/667 450 000  
Fax +91/20/229 292 05  
admin@pmipl-online.com  
www.phoenixmecano.co.in

**Italy**

**Phoenix Mecano S.r.l.**  
Prolungamento, Via G. di Vittorio 11  
I-20065 Inzago (Milan)  
Phone +39/02/953 152 60  
Fax +39/02/953 105 39  
info.pmi@phoenix-mecano.com  
www.phoenix-mecano.it

**Korea (South Korea)**

**Phoenix Mecano Korea Co. Ltd.**  
Seoul Office  
2020 ho, Daelim Acrotel C-dong,  
Dogok-2 dong  
467-6, Kangnam-gu,  
Seoul, Korea 135-971  
Phone +82/2/26 376 922  
Fax +82/2/26 376 925  
info@pmecano.co.kr  
www.pmecano.co.kr

**People's Republic of China**

**Mecano Components (Shanghai) Co. Ltd.**  
No. 1001, JiaQian Road  
Nanxiang, JiaDing District  
201802 Shanghai  
Phone +86/21/691 765 90  
Fax +86/21/691 765 32  
info@mecano.com.cn  
www.mecano.com.cn

**Okin Refined Electric Technology Co. Ltd.**

No. 410, Xinyonglian Road,  
Wangjianjing  
Development Zone, Zhejiang  
314024 Jiaying  
Phone +86/573/822 810 28  
Fax +86/573/822 809 68  
sales@refinedchina.com  
www.refinedchina.com

**Phoenix Mecano**

**Hong Kong Ltd.**  
Suite 2508, Tower 1, Lippo Centre  
89 Queensway  
Hong Kong  
Phone +86/755/837 858 96  
Fax +86/755/837 852 37  
info@phoenix-mecano.hk

**Shenzhen Elcom Trading Co. Ltd.**

1902, 19F Dongfeng Building 2010  
Shennan Road, Shenzhen China  
Phone +86/755/837 856 74  
Fax +86/755/837 852 37

## ADDRESSES

## Production and sales companies

**Romania**

Phoenix Mecano Plastic S.r.l.  
Europa Unita Nr. 10  
RO-550052 Sibiu  
Phone +402/69/241 055  
Fax +402/69/241 210  
pm.office@phoenix-mecano.ro

**Russia**

Moscow representative office  
Rose Systemtechnik GmbH  
Lesnaya str. 43, office 331-332  
RUS-127055 Moskau  
Phone +7/495/ 984 25 11  
Fax +7/495/ 988 76 21  
info@rose-pw.ru  
www.rose-pw.ru

**Scandinavia**

Okin Scandinavia AB  
Box 73, Pålvägen 8  
SE-360 44 Ingelstad  
Phone +46/470/724990  
Fax +46/470/724999  
info@okin.se  
www.okin.se

Phoenix Mecano ApS  
Agerhatten 16 A4  
DK-5220 Odense SØ  
Phone +45/70/70 20 29  
Fax +45/70/22 57 22  
info@phoenix-mecano.dk  
www.phoenix-mecano.dk

**Singapore**

Phoenix Mecano S.E. Asia Pte Ltd.  
53 Ubi Ave 3  
04-01, Colourscan Building  
Singapore 408863  
Phone +65/674 916 11  
Fax +65/67496766/674 967 49  
pmsea@pmecano.com.sg  
www.phoenixmecano.com.sg

**Spain**

Sistemas Phoenix Mecano  
España S.A.  
Pol. El Olivar, naves 15-16  
Carretera de Logroño, Km. 247  
E-50011 Zaragoza  
Phone +34/976/786 080  
Fax +34/976/787 088  
info@phoenix-mecano.es  
www.phoenix-mecano.es

**Switzerland**

Phoenix Mecano  
Komponenten AG  
Hofwisenstrasse 6  
CH-8260 Stein am Rhein  
Phone +41/52/742 75 00  
Fax +41/52/742 75 90  
info@phoenix-mecano.ch  
www.phoenix-mecano.ch

**Taiwan**

Branch of  
Phoenix Mecano S.E. Asia Pte Ltd.  
Taipei World Trade Center  
Exhibition Hall  
Room 4E-12  
No. 5, Hsin-Yi Road  
Sec. 5, Taipei, Taiwan 110  
pmtwn@pmecano.com.tw

**Thailand**

Representative office of  
Phoenix Mecano S.E. Asia Pte Ltd.  
Kitsiri Building, Room C, 2nd Floor  
1054/14 New Petchburi Road,  
Makkasan, Ratchatewi,  
Bangkok 10400, Thailand  
Phone +66/2/254 70 76  
Fax +66/2/254 70 78  
pmthai@pmecano.com.sg

**Tunisia**

Phoenix Mecano Digital  
Tunisie S.à.r.l.  
23, Rue Jamel Abdennacer Z.I.  
TN-2084 Borj-Cedria  
Phone +21/671/430 666  
Fax +21/671/430 267

**Phoenix Mecano**

ELCOM S.à.r.l.  
Iotis Med Ridha Bouhejba Z.I.  
TN-1100 Djebel El Ouest-Zaghouan  
Phone +21/672/640 089  
Fax +21/672/640 589

**Phoenix Mecano Hartu S.à.r.l.**

Rue Annaba Lot 119-Z.I.  
TN-2013 Ben Arous  
Phone +21/671/387 802  
Fax +21/671/387 928

**Turkey**

Phoenix Mecano Mazaka  
Endüstriyel Ürünler San ve Tic AŞ  
İvedik OSB 1434. St. No:5  
TR-06374 Yenimahalle/Ankara  
Phone +90/312/3942106  
Fax +90/312/3942107  
info@mazaka.com.tr  
www.mazaka.com.tr

**United Arab Emirates**

Rose Systemtechnik  
Middle East (FZE)  
125M2 Warehouse  
P.O. Box 8993  
Sharjah – U.A.E.  
Phone +971/50/270 39 85  
Fax +971/6/551 56 21  
surajshreya@hotmail.com  
www.ROSE-MEast.com

**USA**

Okin America Inc.  
291 CDF Boulevard  
Shannon, MS 38868  
Phone +1/662/566 10 00  
Fax +1/662/566 00 09  
sales@okinamerica.net  
www.okinamerica.net

**Phoenix Mecano Inc.**

7330 Executive Way  
Frederick, Maryland  
Md. 21704-8353  
Phone +1/301/696 94 11  
Fax +1/301/696 94 94  
PMinfo@pm-usa.com  
www.pm-usa.com

**Branch of**

Phoenix Mecano Inc.  
2000 S. Grove Avenue  
Suite 106  
Ontario, California 91761  
Phone +1/800/325 39 91  
Fax +1/909/930 51 91  
PMinfo@pm-usa.com  
www.pm-usa.com

**WIENER Plein & Baus Corp.**

300 East Auburn Ave.  
Springfield, OH 45505  
Phone +1/937/32 424 20  
Fax +1/937/32 424 25  
aruben@wiener-us.com  
www.wiener-us.com

# PRODUCTS OF THE PHOENIX MECANO GROUP

## ENCLOSURES

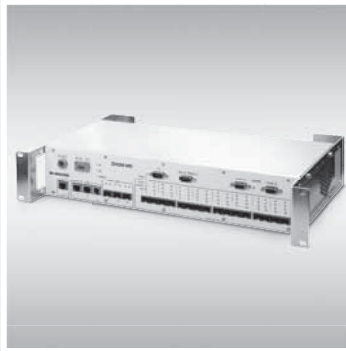

Customised metal enclosure for use in communication technology.



With their improved surface feel and back-lit keys, ProfiLine keypads are ideal for use in dark environments.



Customised stainless-steel enclosure for housing a pitch control, a device that optimally pitches (turns) the blades of a wind turbine according to the wind strength.



## MECHANICAL COMPONENTS

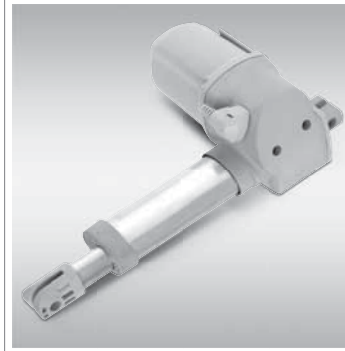

Low access positions and the need to accommodate ever larger patients are key features of modern nursing and hospital beds. With its adjustment load of 8 000 N and its compact dimensions, the powerful single drive is ideally suited to these requirements.

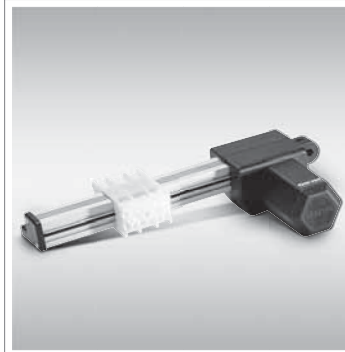

All-purpose, low-noise single drive for powering standing aids in chairs. Thanks to its actuating block, the drive combines maximum stroke range with small space requirements.

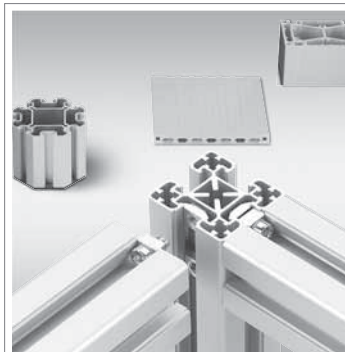

Profile technology products. Requiring no machining, the connection system offers maximum flexibility and reliability in your application.



ELCOM/EMS

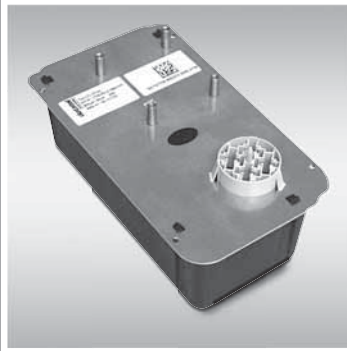

AC inverter choke for use in solar power installations.

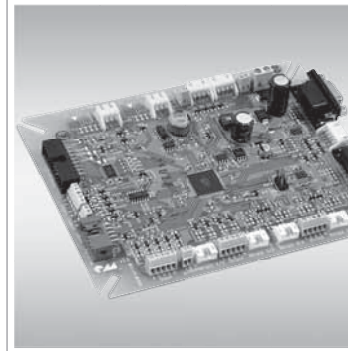

All-purpose control system. It uses the same hardware, with only the software varying according to the type of application (money changing machines, self-service checkouts, barrier control systems).

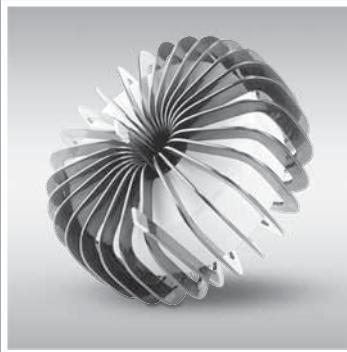

Iron powder core choke to suppress radio interference in inverters, featuring high current load and low winding capacity.



Standard terminal block with opening for performance testing with test probes.

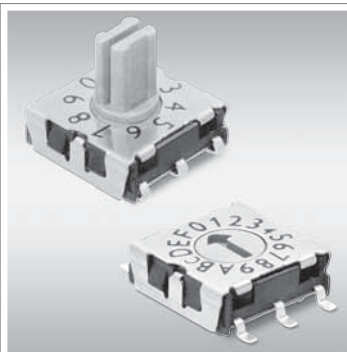

Miniaturisation of equipment is an ongoing trend. Circuit boards are becoming ever smaller, with a corresponding reduction in the space available for electro-mechanical components. Consequently, new smaller rotary coding switches are being used in many electrical applications.



Very compact multi-channel low and high voltage power supply system. All channels are individually controlled and monitored. The system is used to control the detectors of big particle physics experiments in scientific research facilities like CERN in Geneva.



Connection box for train drive and control technology applications. Smart, reliable systems control and monitor energy supply and vehicle operation.





**Imprint**

Editor Ruoss Markus  
Corporate Communications  
CH-8808 Pfäffikon

Concept, design, editing and production  
PETRANIX  
Corporate and Financial Communications AG  
CH-8134 Adliswil – Zurich

Photography  
Management photo  
Scanderbeg Sauer Photography  
CH-8006 Zurich

Image editing DETAIL AG  
CH-8032 Zurich

Printed by Neidhart + Schön Group AG  
CH-8037 Zurich

**Group headquarters**

Phoenix Mecano AG  
Hofwisenstrasse 6  
P.O. Box  
CH-8260 Stein am Rhein

**Contact address**

Phoenix Mecano Management AG  
Lindenstrasse 23  
CH-8302 Kloten  
Phone +41/(0)43 255 42 55  
Fax +41/(0)43 255 42 56  
info@phoenix-mecano.com  
www.phoenix-mecano.com

This annual report is also  
available in German. The German  
version is binding.